

P-8521-1  
29196

DETAIL OF "A"  
SCALE 6:1

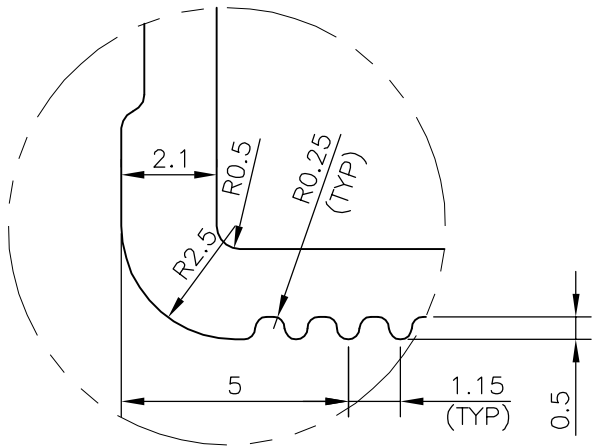

DETAIL OF "B"  
SCALE 6:1

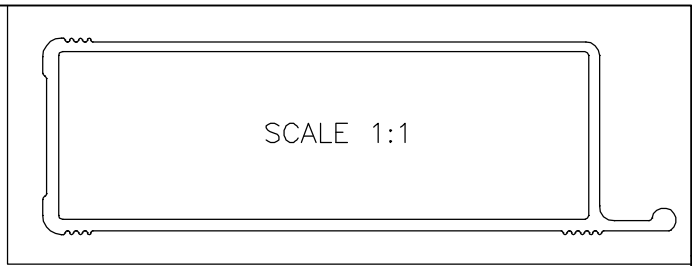
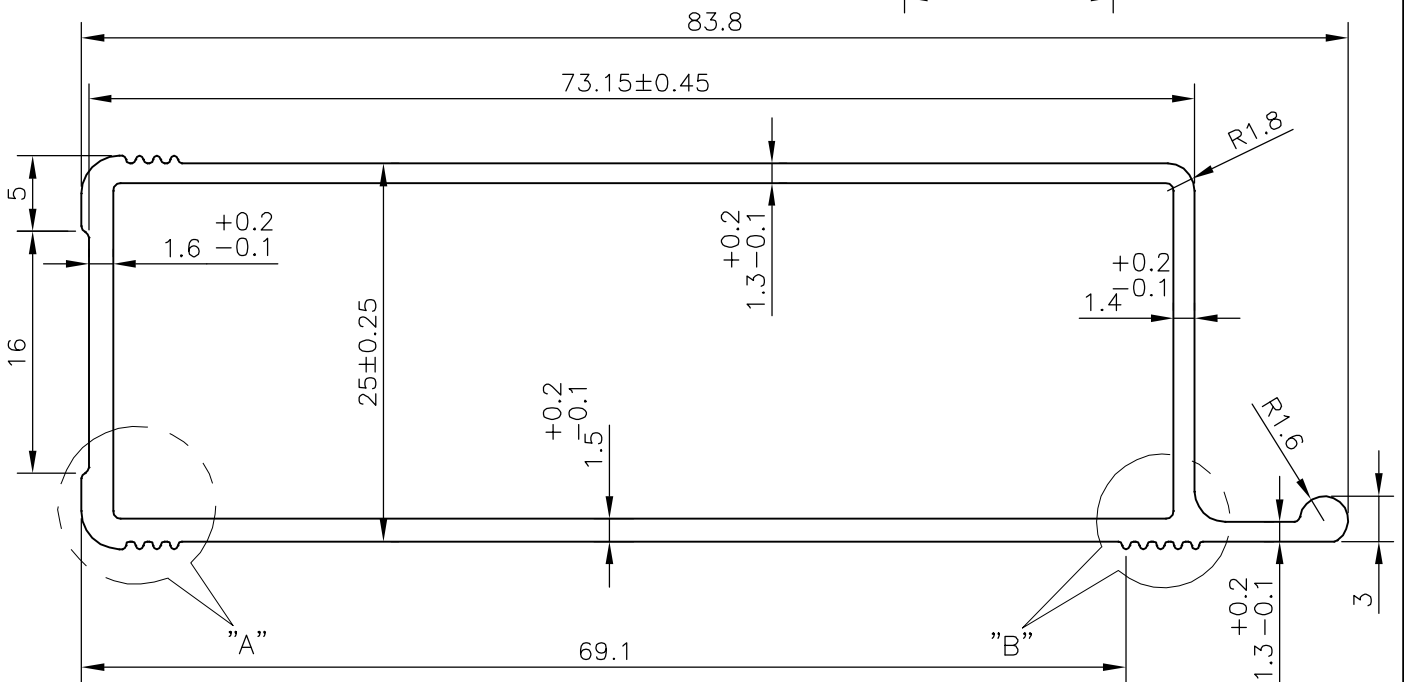
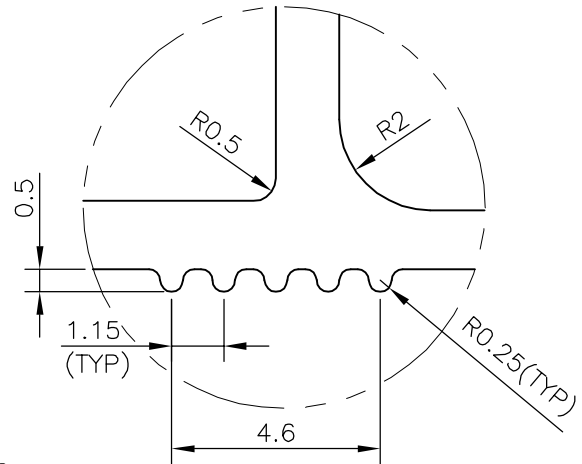

SYMBOL OF QUALITY  
AN ISO 9001 COMPANY

**JINDAL ALUMINIUM LTD.**  
BANGALORE-560073 (INDIA)

	NAME	DATE
DRAWN	PRASANNA.H	06-09-2008
CHECKED		
APPROVED		

- ALL DIMENSIONS ARE IN mm.
- ROUND OFF ALL SHARP CORNERS WITH 0.40 mm.
- TOLERANCES WILL BE AS PER DIN EN 12020-2 UNLESS OTHERWISE SPECIFIED

SCALE	2:1
AREA mm <sup>2</sup>	296.573
PERIMETER mm.	223.438
WEIGHT kg/m	0.801

PARTY'S NAME	ZARGES TUBESCA INDIA PVT. LTD., ANDHRA PRADESH
PARTY'S DRAWING No.	21009
ALLOY & TEMPER	6063 T66
DESCRIPTION	RECTANGULAR TUBE WITH CORNER RADII-MISC.

DRAWING No.	SECTION No.
P-8521-1	-
29196	29196