

P-8622

29221

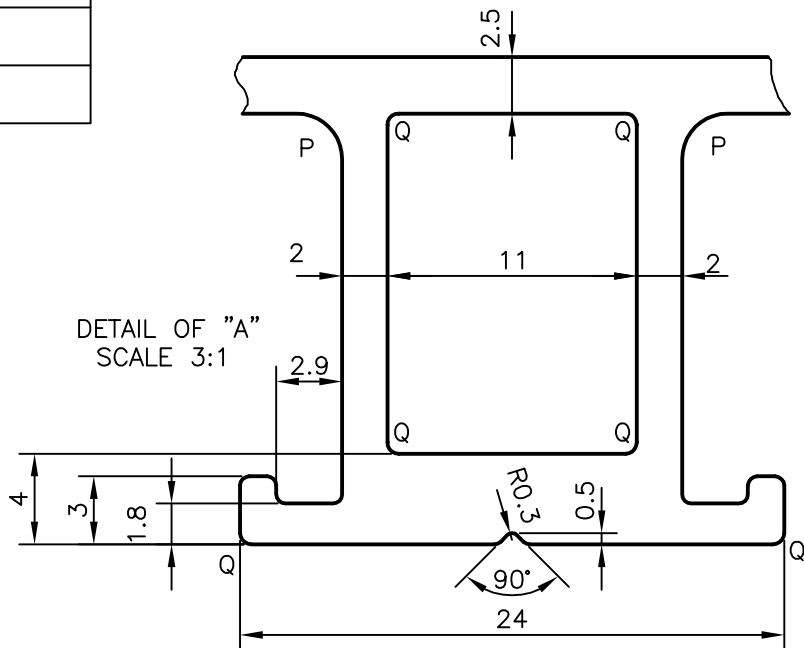

DETAIL OF "B"
SCALE 3:1

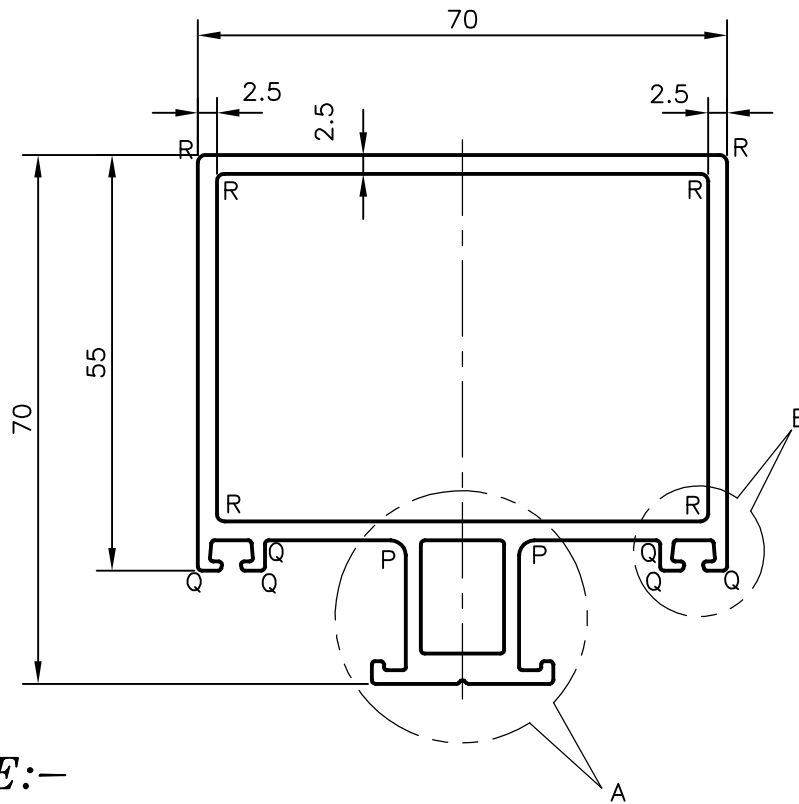
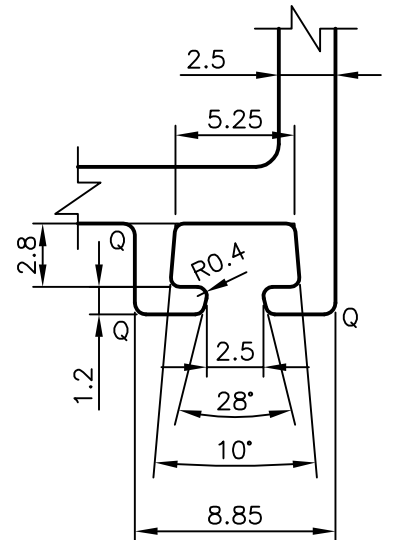

NOTE:-

1. P = R2.0 mm (2 PLACES)
2. Q = R0.50 mm (12 PLACES)
3. R = R1.0 mm (6 PLACES)



SYMBOL OF QUALITY
AN ISO 9001 COMPANY

JINDAL ALUMINIUM LTD.
BANGALORE-560073 (INDIA)

	NAME	DATE
DRAWN	ABHARANI	08-09-2008
CHECKED		
APPROVED		
SCALE		1:1
AREA	mm ²	755.622
PERIMETER	mm.	338.39
WEIGHT	kg/m	2.040
DRAWING No.	SECTION No.	
P-8622	-	
29221	29221	

1. ALL DIMENSIONS ARE IN mm.	
2. ROUND OFF ALL SHARP CORNERS WITH 0.40 mm.	
3. TOLERANCES WILL BE AS PER IS:6477-1983 UNLESS OTHERWISE SPECIFIED	
PARTY'S NAME	INNOVATORS FACADE SYSTEMS PVT. LTD., THANE, MAHARASHTRA
PARTY'S DRAWING No.	EXT-85
ALLOY & TEMPER	HE9 WP
DESCRIPTION	CURTAIN WALL SECTION-TRANSOM