

P-8643

29238

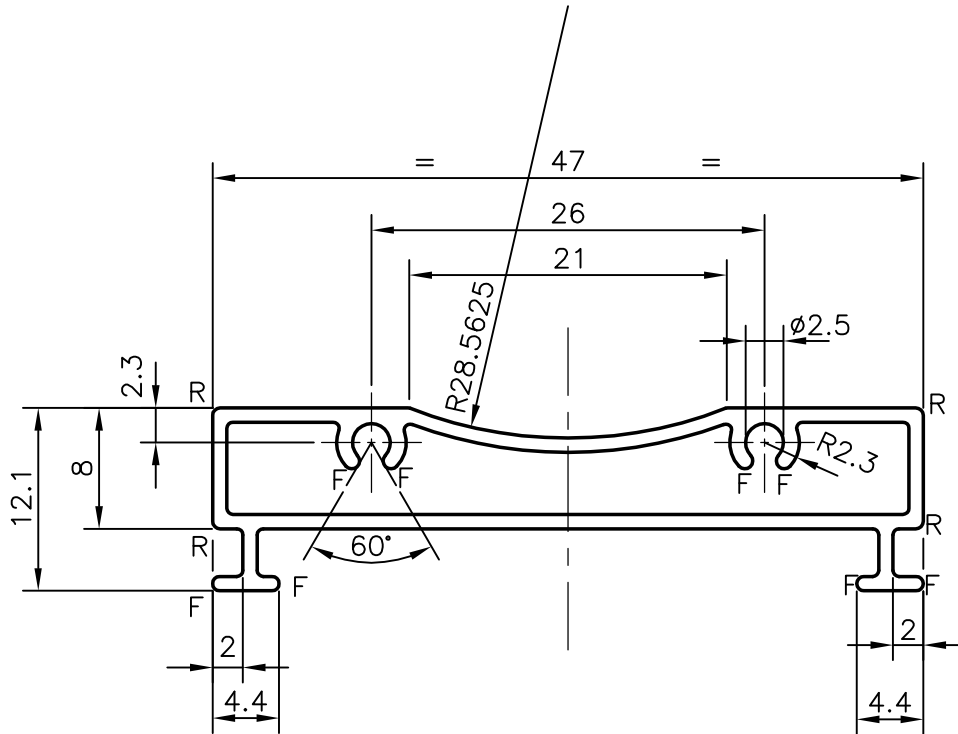

SCALE 1:1



NOTE:-

- 1. R = RADIUS 0.50 mm (4 PLACES)
- 2. F = FULL RADIUS (8 PLACES)
- 3. GENERAL WALL THICKNESS = 0.95 mm



SYMBOL OF QUALITY
AN ISO 9001 COMPANY

JINDAL ALUMINIUM LTD.
BANGALORE-560073 (INDIA)

	NAME	DATE
DRAWN	ABHARANI	15-09-2008
CHECKED		
APPROVED		

- 1. ALL DIMENSIONS ARE IN mm.
- 2. ROUND OFF ALL SHARP CORNERS WITH 0.40 mm.
- 3. TOLERANCES WILL BE AS PER IS:6477-1983 UNLESS OTHERWISE SPECIFIED

SCALE	2:1
AREA mm ²	130.065
PERIMETER mm.	136.838
WEIGHT kg/m	0.351

PARTY'S NAME	MADHU INDIA LIMITED, LUCKNOW
PARTY'S DRAWING No.	DC-418
ALLOY & TEMPER	HE9 WP
DESCRIPTION	MISC. SECTION-HOLLOW

DRAWING No.	SECTION No.
P-8643	-
29238	29238