

P-8666-2

29241

SCALE 1:1

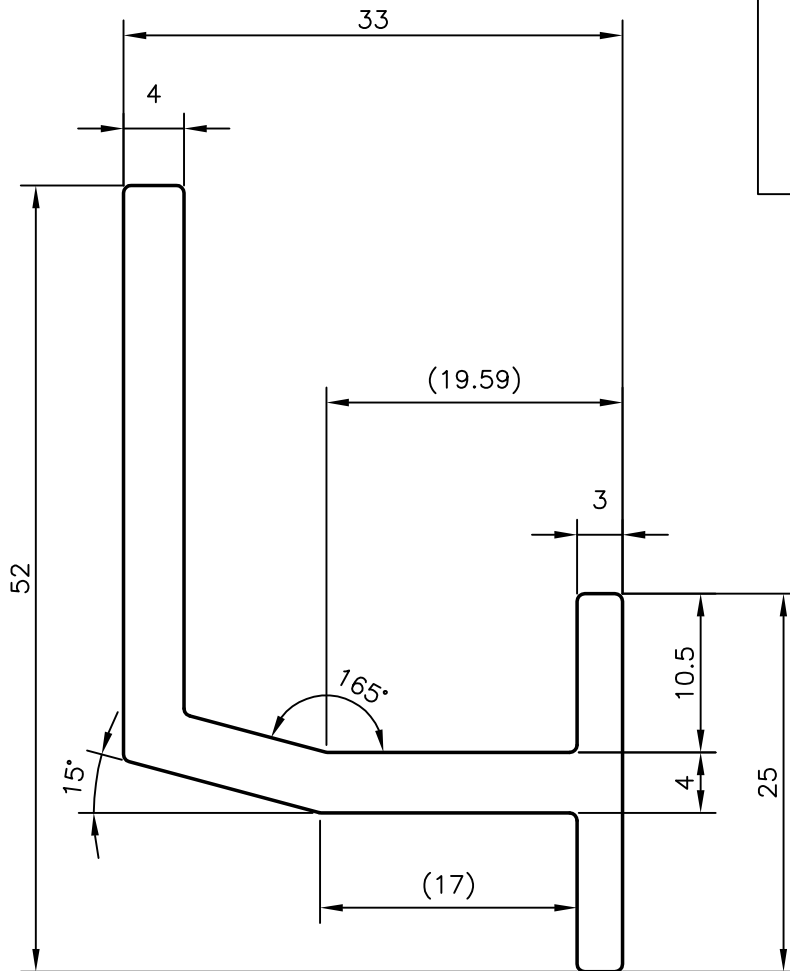

NOTE:-

UNSPECIFIED CORNER RADII = 0.50 mm



SYMBOL OF QUALITY
AN ISO 9001 COMPANY

JINDAL ALUMINIUM LTD.
BANGALORE-560073 (INDIA)

	NAME	DATE
DRAWN	ABHARANI	20-10-2008
CHECKED		
APPROVED		
SCALE		2:1
AREA mm ²		334.007
PERIMETER mm.		183.842
WEIGHT kg/m		0.902
DRAWING No.		SECTION No.
P-8666-2		-
29241		29241

1. ALL DIMENSIONS ARE IN mm.
2. ROUND OFF ALL SHARP CORNERS WITH 0.50 mm.
3. TOLERANCES WILL BE AS PER IS:3965-1981 UNLESS OTHERWISE SPECIFIED

PARTY'S NAME	GLASS WALL SYSTEMS, MUMBAI
PARTY'S DRAWING No.	AS PER DRAWING
ALLOY & TEMPER	HE9 WP
DESCRIPTION	MISC. SOLID PROFILE