

P-8767

29245

DETAIL OF "B"  
SCALE 2:1

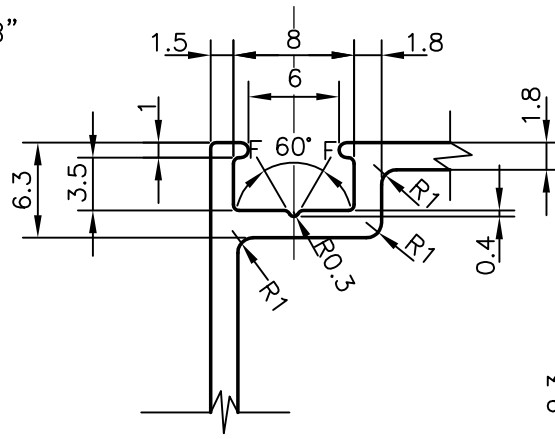

DETAIL OF "A"  
SCALE 2:1

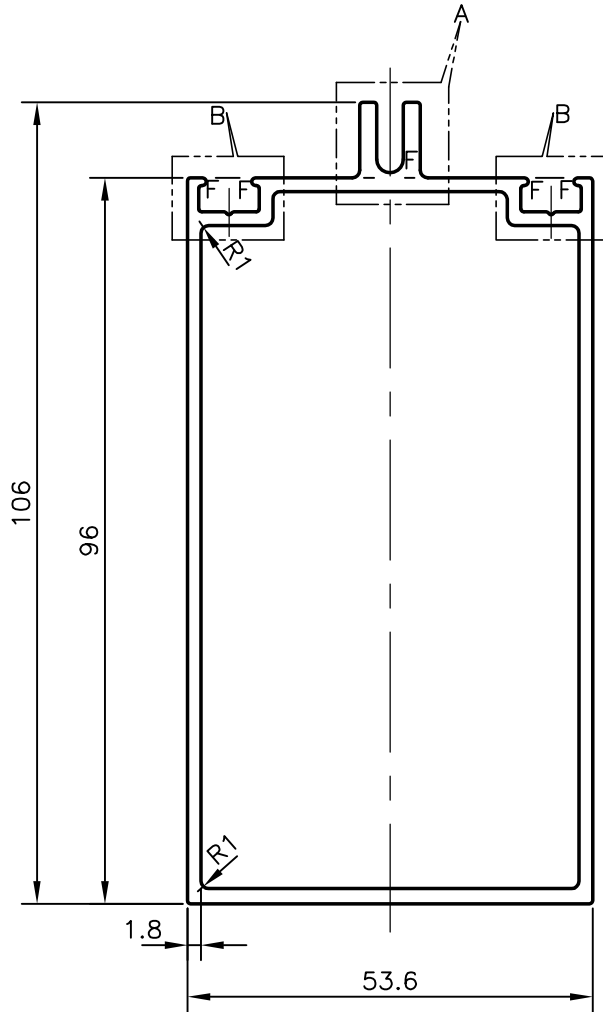
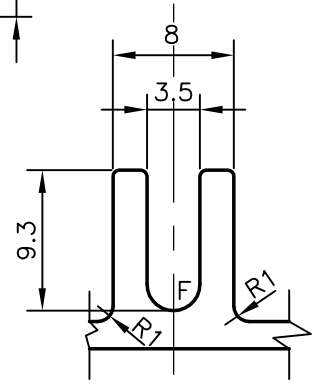

**NOTE:-**

*F = FULL RADIUS (5 PLACES)*



SYMBOL OF QUALITY  
AN ISO 9001 COMPANY

**JINDAL ALUMINIUM LTD.**  
BANGALORE-560073 (INDIA)

	NAME	DATE
DRAWN	ABHARANI	31-10-2008
CHECKED		
APPROVED		

1. ALL DIMENSIONS ARE IN mm.
2. ROUND OFF ALL SHARP CORNERS WITH 0.4 mm.
3. TOLERANCES WILL BE AS PER IS:6477-1983 UNLESS OTHERWISE SPECIFIED

SCALE	1:1
AREA mm <sup>2</sup>	602.291
PERIMETER mm.	357.598
WEIGHT kg/m	1.626

PARTY'S NAME GENERAL CATEGORY, COCHIN MARKET

PARTY'S DRAWING No. AS PER DRAWING

ALLOY & TEMPER HE9 WP

DESCRIPTION CURTAIN WALL SECTION

DRAWING No.	SECTION No.
P-8767	-
29245	29245
-	-