

P-8781

29248

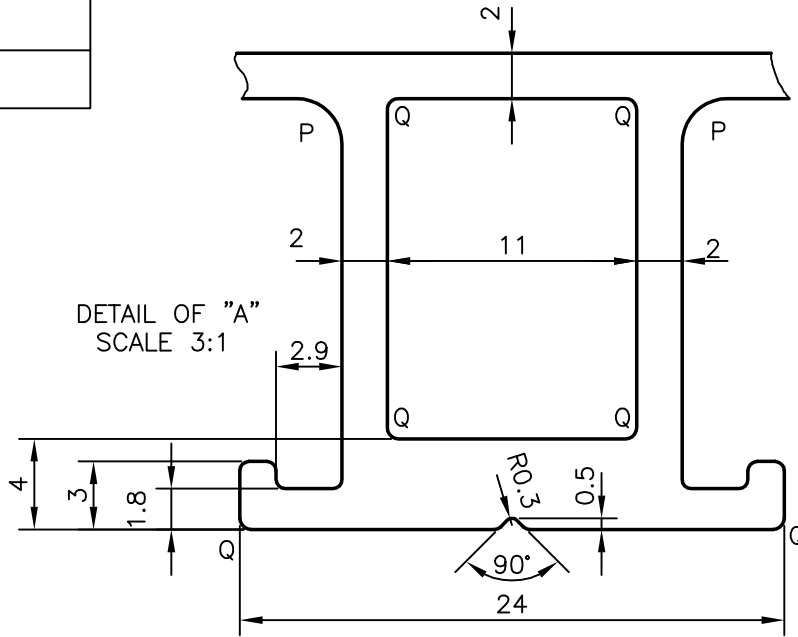

DETAIL OF "B"  
SCALE 3:1

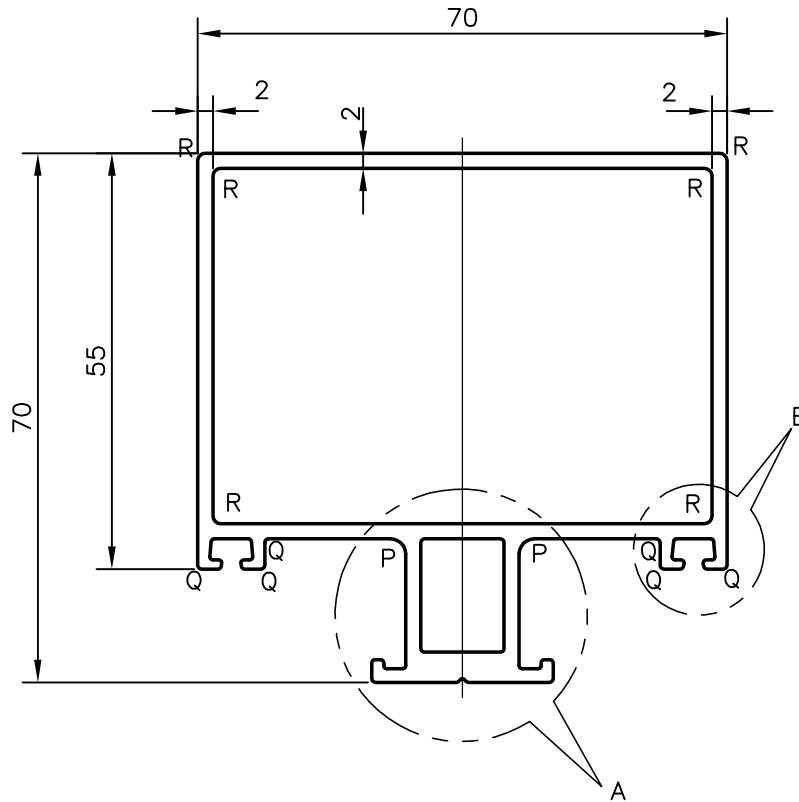
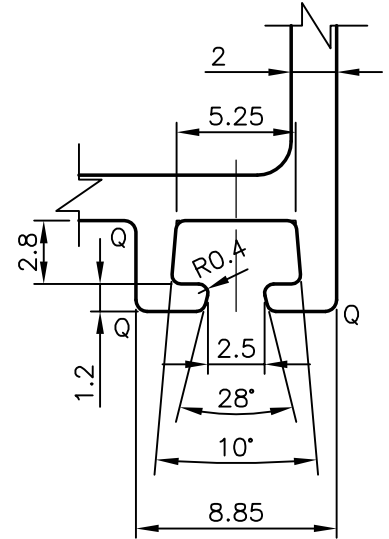

- 1. P = R2.0 mm (2 PLACES)
- 2. Q = R0.50 mm (12 PLACES)
- 3. R = R1.0 mm (6 PLACES)



SYMBOL OF QUALITY  
AN ISO 9001 COMPANY

**JINDAL ALUMINIUM LTD.**  
BANGALORE-560073 (INDIA)

	NAME	DATE
DRAWN	ABHARANI	07-11-2008
CHECKED		
APPROVED		

- 1. ALL DIMENSIONS ARE IN mm.
- 2. ROUND OFF ALL SHARP CORNERS WITH 0.40 mm.
- 3. TOLERANCES WILL BE AS PER IS:6477-1983 UNLESS OTHERWISE SPECIFIED

SCALE	1:1
AREA mm <sup>2</sup>	643.622
PERIMETER mm.	338.39
WEIGHT kg/m	1.738

PARTY'S NAME	INNOVATORS FACADE SYSTEMS PVT. LTD., THANE
PARTY'S DRAWING No.	EXT-92
ALLOY & TEMPER	HE9 WP
DESCRIPTION	CURTAIN WALL SECTION-TRANSOM

DRAWING No.	SECTION No.
P-8781	-
29248	29248