

P-8803

29251

DETAIL OF "A"
SCALE 3:1

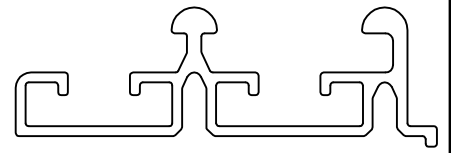

SCALE 1:1

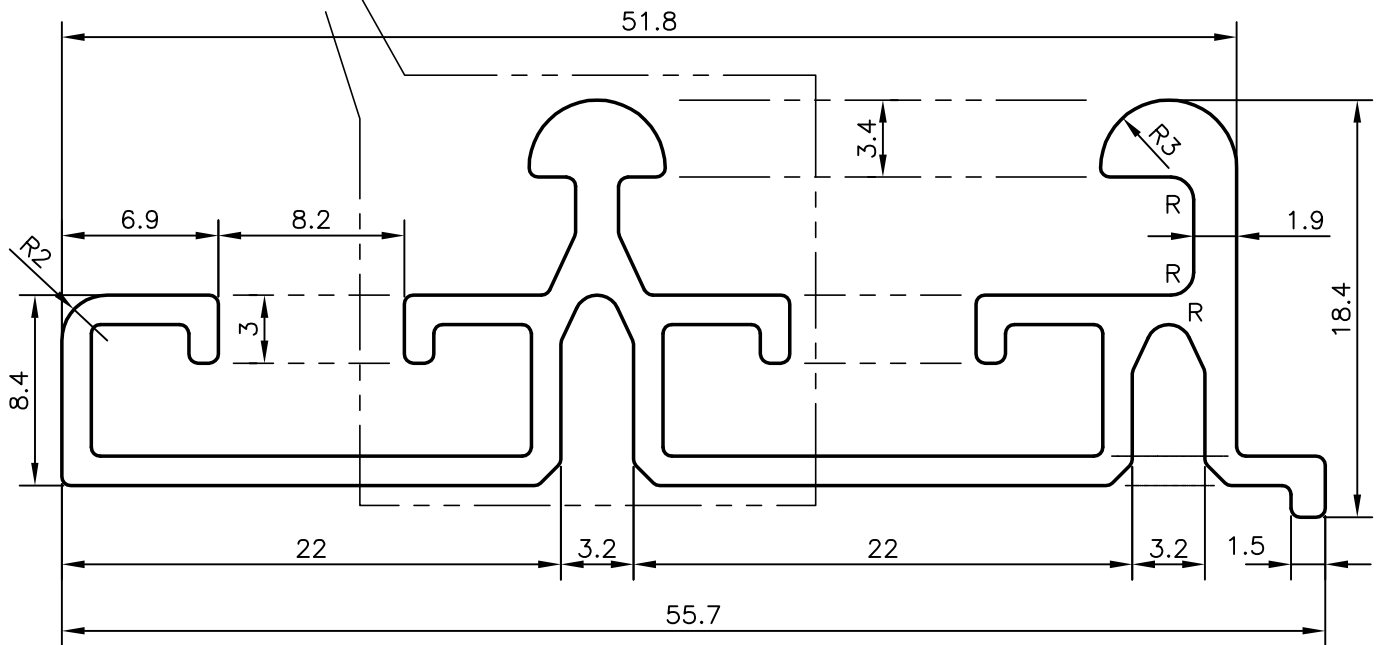
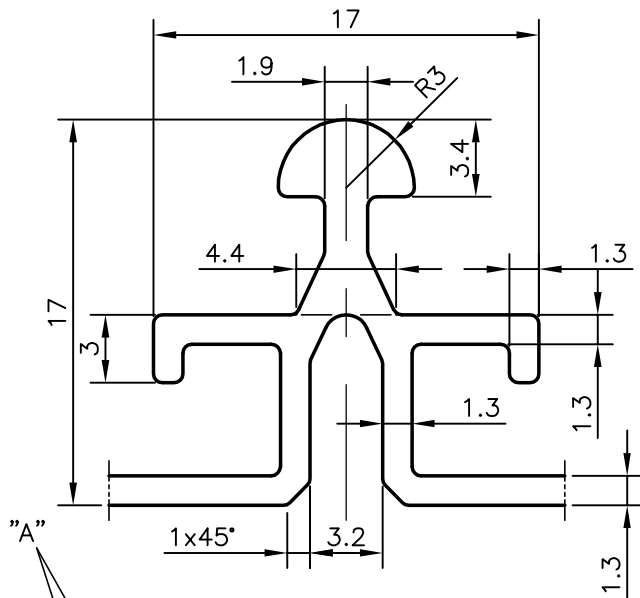

R = R1.0 mm (4 PLACES)

UNSPECIFIED WALL THICKNESS = 1.30 mm



SYMBOL OF QUALITY
AN ISO 9001 COMPANY

JINDAL ALUMINIUM LTD.
BANGALORE-560073 (INDIA)

	NAME	DATE
DRAWN	PRASANNA.H	13-11-2008
CHECKED		
APPROVED		

1. ALL DIMENSIONS ARE IN mm.
2. ROUND OFF ALL SHARP CORNERS WITH 0.40 mm.
3. TOLERANCES WILL BE AS PER IS:3965-1981 UNLESS OTHERWISE SPECIFIED

SCALE	3:1
AREA mm ²	213.077
PERIMETER mm.	278.612
WEIGHT kg/m	0.575

PARTY'S NAME	HAFELE INDIA PVT. LTD., THANE
PARTY'S DRAWING No.	AS PER SAMPLE
ALLOY & TEMPER	HE9 WP
DESCRIPTION	MISC. SECTION

DRAWING No.	SECTION No.
P-8803	-
29251	29251