

P-8804

29252

DETAIL OF "A"
SCALE 3:1

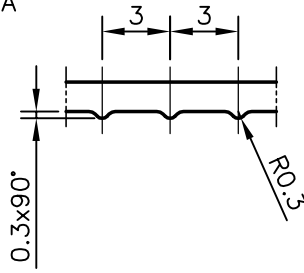

SCALE 1:1

DETAIL OF "B"
SCALE 3:1

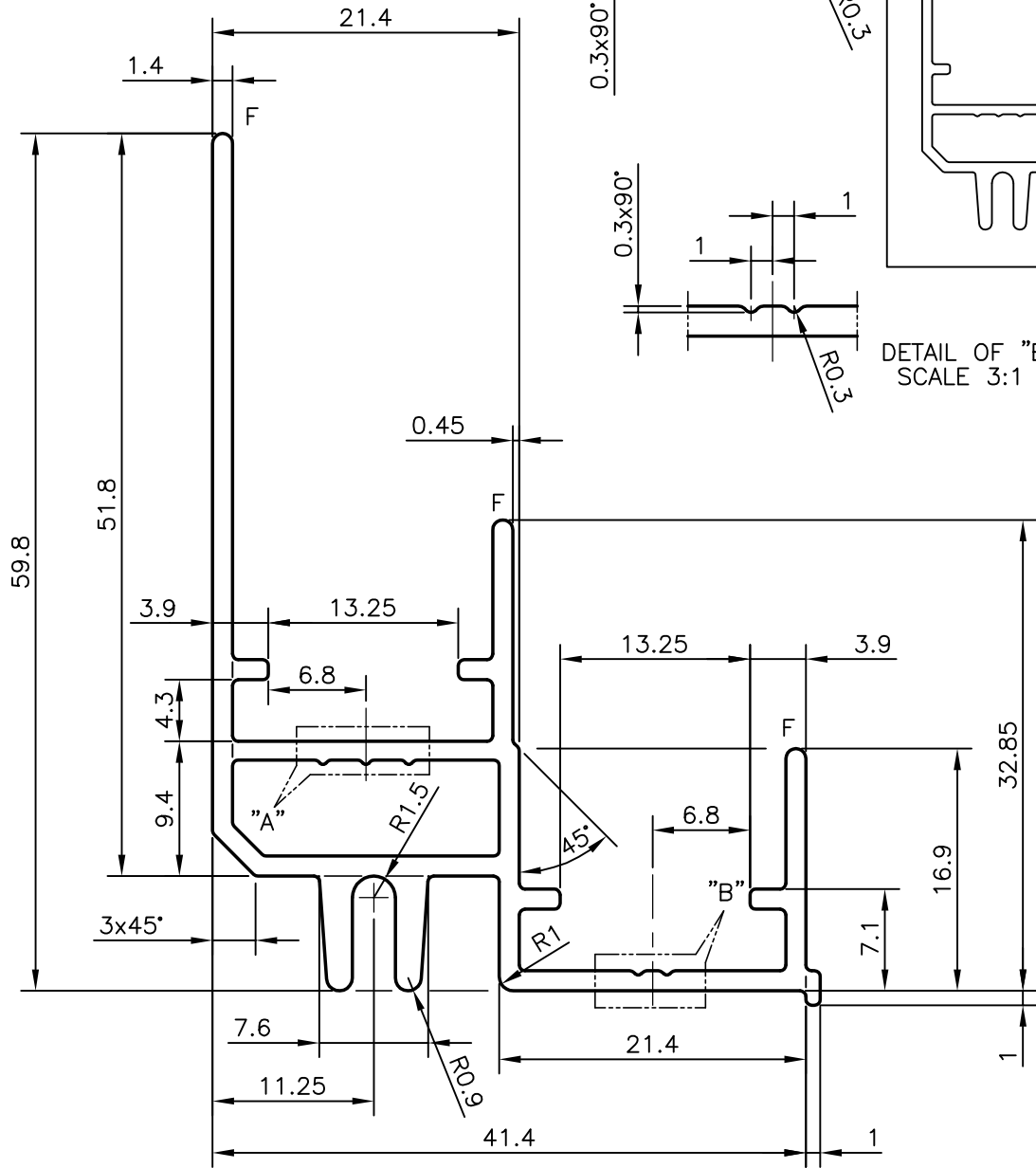
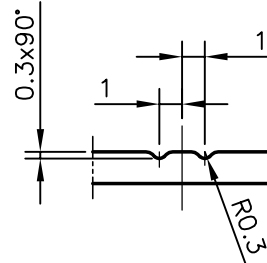

F = FULL RADIUS (3 PLACES)
UNSPECIFIED WALL THICKNESS = 1.40

PLEASE SPECIFY THE EXPOSED SURFACE IN THE DRAWING WHEREVER BETTER FINISH REQUIRED.



SYMBOL OF QUALITY
AN ISO 9001 COMPANY

JINDAL ALUMINIUM LTD.
BANGALORE-560073 (INDIA)

	NAME	DATE
DRAWN	PRASANNA.H	13-11-2008
CHECKED		
APPROVED		

1. ALL DIMENSIONS ARE IN mm.
2. ROUND OFF ALL SHARP CORNERS WITH 0.40 mm.
3. TOLERANCES WILL BE AS PER IS:6477-1983 UNLESS OTHERWISE SPECIFIED

SCALE	2:1
AREA mm ²	265.189
PERIMETER mm.	308.302
WEIGHT kg/m	0.716

PARTY'S NAME	HAFELE INDIA PVT. LTD., THANE
PARTY'S DRAWING No.	AS PER SAMPLE
ALLOY & TEMPER	HE9 WP
DESCRIPTION	MISC. SECTION

DRAWING No.	SECTION No.
P-8804	-
29252	29252