

P-6438

X598

29259

GENERAL WALL THICKNESS 2.0 mm (TYP)

F= FULL RADIUS (6) PLACE

R= 2.0 RADIUS (9) PLACE

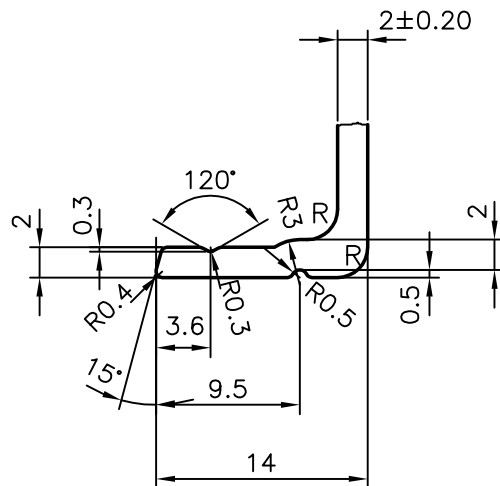
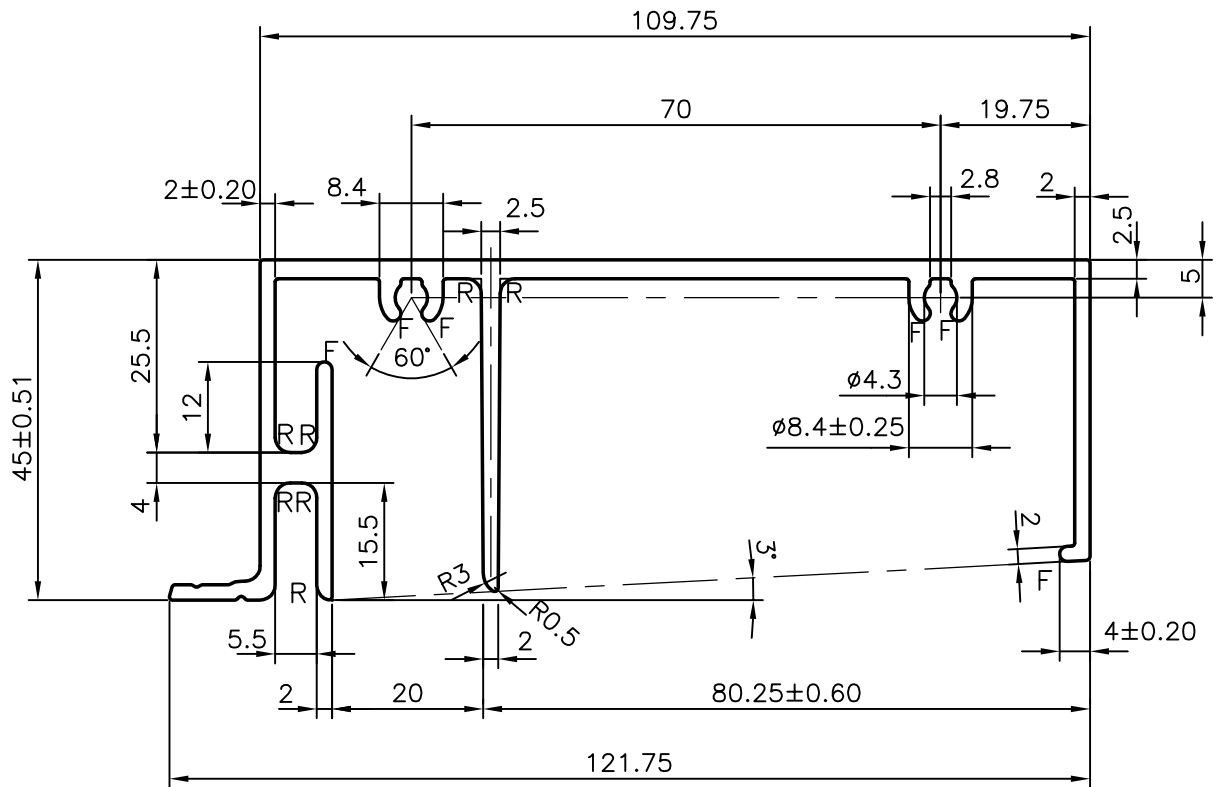

SYMBOL OF QUALITY
AN ISO 9001 COMPANY

JINDAL ALUMINIUM LTD.
BANGALORE-560073 (INDIA)

	NAME	DATE
DRAWN	J.P.KAUSHIK	31-05-2006
CHECKED		
APPROVED		

1. ALL DIMENSIONS ARE IN mm.
2. ROUND OFF ALL SHARP CORNERS WITH 0.40 mm.
3. TOLERANCES WILL BE AS PER IS:3965-1981 UNLESS OTHERWISE SPECIFIED

SCALE	1:1
AREA mm ²	693.385
PERIMETER mm.	591.709
WEIGHT kg/m	1.872

PARTY'S NAME	ALUPLEX INDIA PVT LTD. NAVI MUMBAI
PARTY'S DRAWING No.	AS PER DRAWING
ALLOY & TEMPER	HE9 WP
DESCRIPTION	MISC. SECTION

DRAWING No.	SECTION No.
P-6438	-
X598	X598
29259	29259