

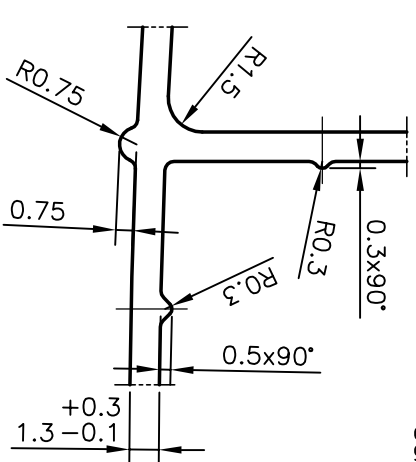

P-8953-2

29292

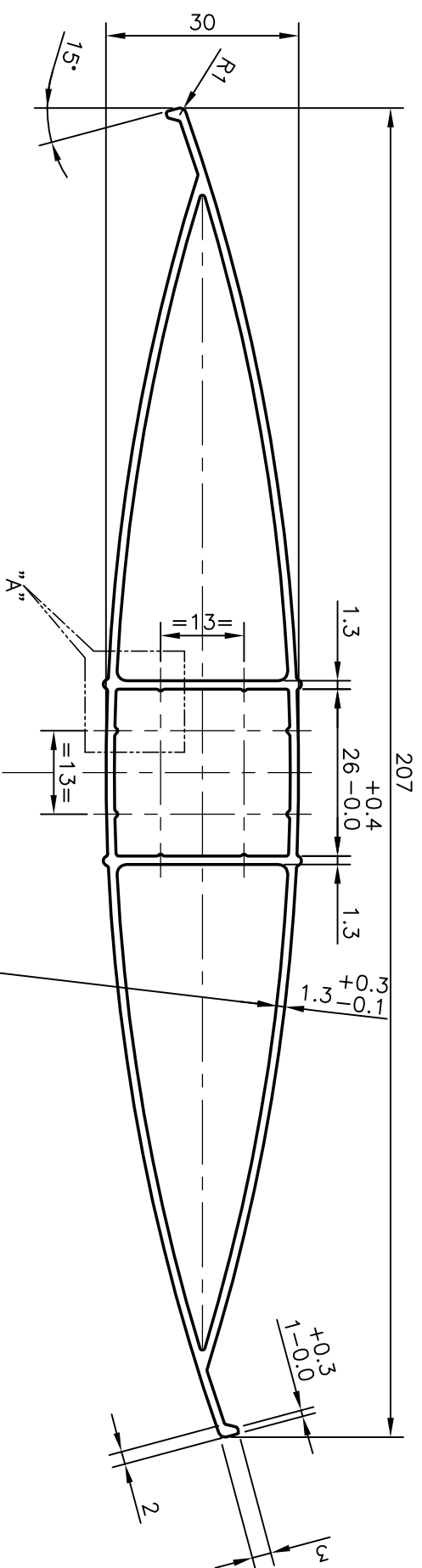

DETAIL OF "A"  
SCALE 3:1

UNSPECIFIED WALL THICKNESS =  $1.30^{+0.3}_{-0.1}$  mm

 SYMBOL OF QUALITY AN ISO 9001 COMPANY		<b>JINDAL ALUMINIUM LTD.</b> BANGALORE-560073 (INDIA)		NAME	DATE
1. ALL DIMENSIONS ARE IN mm. 2. ROUND OFF ALL SHARP CORNERS WITH 0.40 mm. 3. TOLERANCES WILL BE AS PER IS:6477-1983 UNLESS OTHERWISE SPECIFIED		DRAWN	PRASANNA.H	03-01-2009	
PARTY'S NAME	BATLIBOI LTD., SURAT	CHECKED			
PARTY'S DRAWING No.	133935/04	APPROVED			
ALLOY & TEMPER	6060 T5	SCALE		1:1	
DESCRIPTION	DAMPER FIN SECTION	AREA mm <sup>2</sup>		600.457	
		PERIMETER mm.		431.528	
		WEIGHT kg/m		1.621	
		DRAWING No.		SECTION No.	
		P-8953-2		-	
		29292		29292	