

P-9006

29298

DETAIL OF "D"
SCALE 3:1

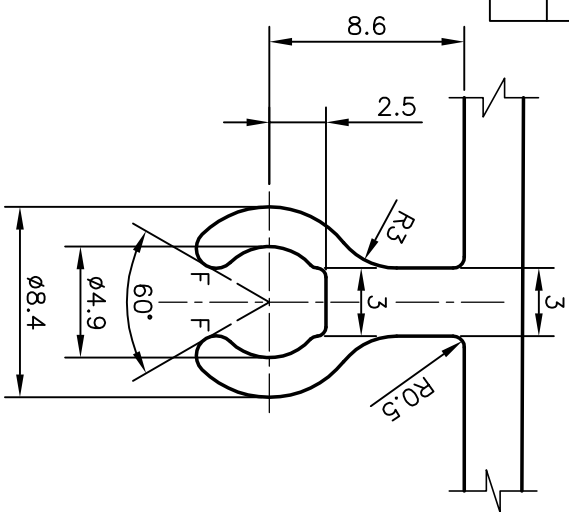

DETAIL OF "A"
SCALE 3:1

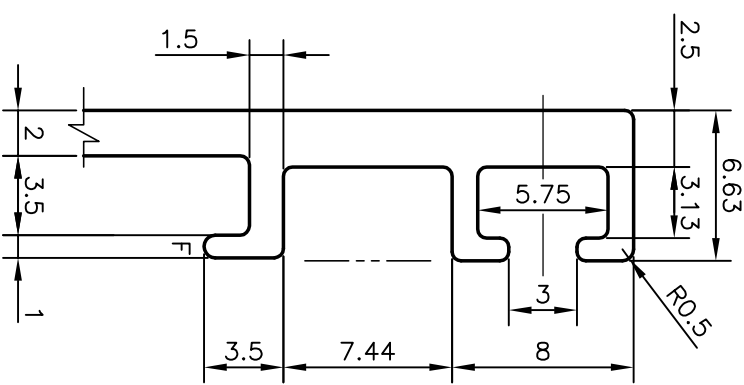

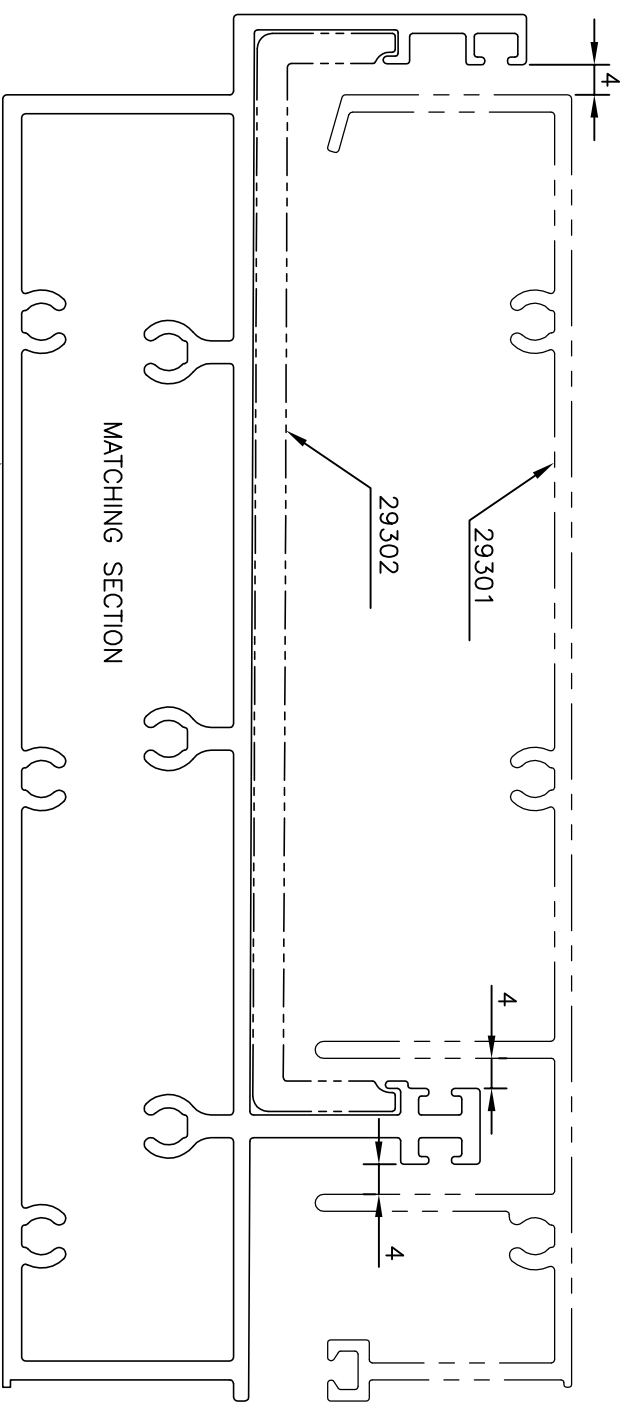
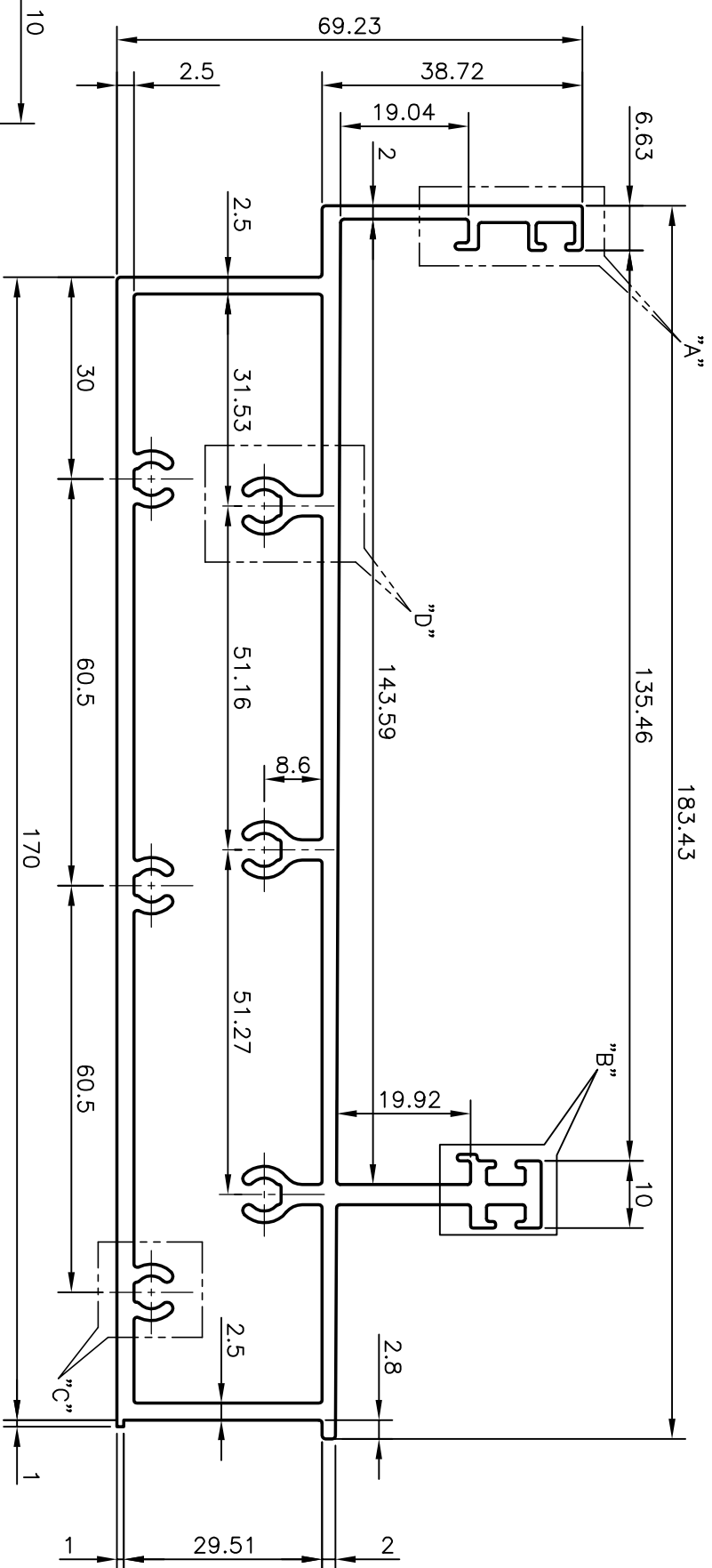
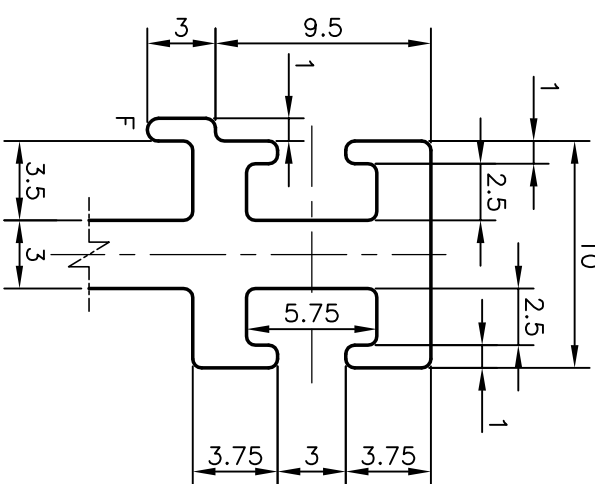

DETAIL OF "B"
SCALE 3:1

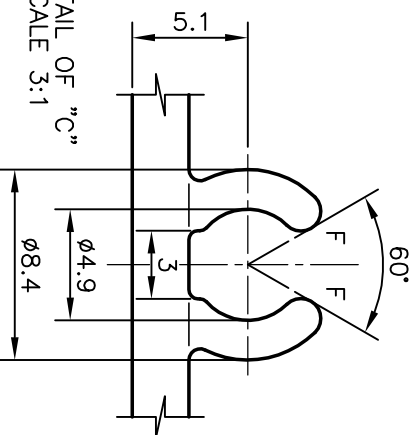

F = FULL RADIUS (2 PLACES)

DETAIL OF "C"
SCALE 3:1



 <p>SYMBOL OF QUALITY AN ISO 9001 COMPANY</p>		<p>JINDAL ALUMINIUM LTD. BANGALORE-560073 (INDIA)</p>	
<p>1. ALL DIMENSIONS ARE IN mm. 2. ROUND OFF ALL SHARP CORNERS WITH 0.40 mm. 3. TOLERANCES WILL BE AS PER IS:6477-1983 UNLESS OTHERWISE SPECIFIED</p>		<p>SCALE 1:1</p>	
<p>PARTY'S NAME GLASS WALL SYSTEMS, MUMBAI</p>		<p>AREA mm² 1431.566</p>	
<p>PARTY'S DRAWING No. AS PER DRAWING</p>		<p>PERIMETER mm. 637.767</p>	
<p>ALLOY & TEMPER HE9 WP</p>		<p>WEIGHT kg/m 3.865</p>	
<p>DESCRIPTION CURTAIN WALL-CUTTER SECTION</p>		<p>DRAWING No. SECTION No.</p>	
<p>PARTY'S DRAWING No. 29298</p>		<p>DRAWING No. SECTION No. - -</p>	
<p>NAME RAGHAVENDRA</p>		<p>DATE 05-02-2009</p>	
<p>CHECKED</p>		<p>APPROVED</p>	