

P-6623
S1851
29311

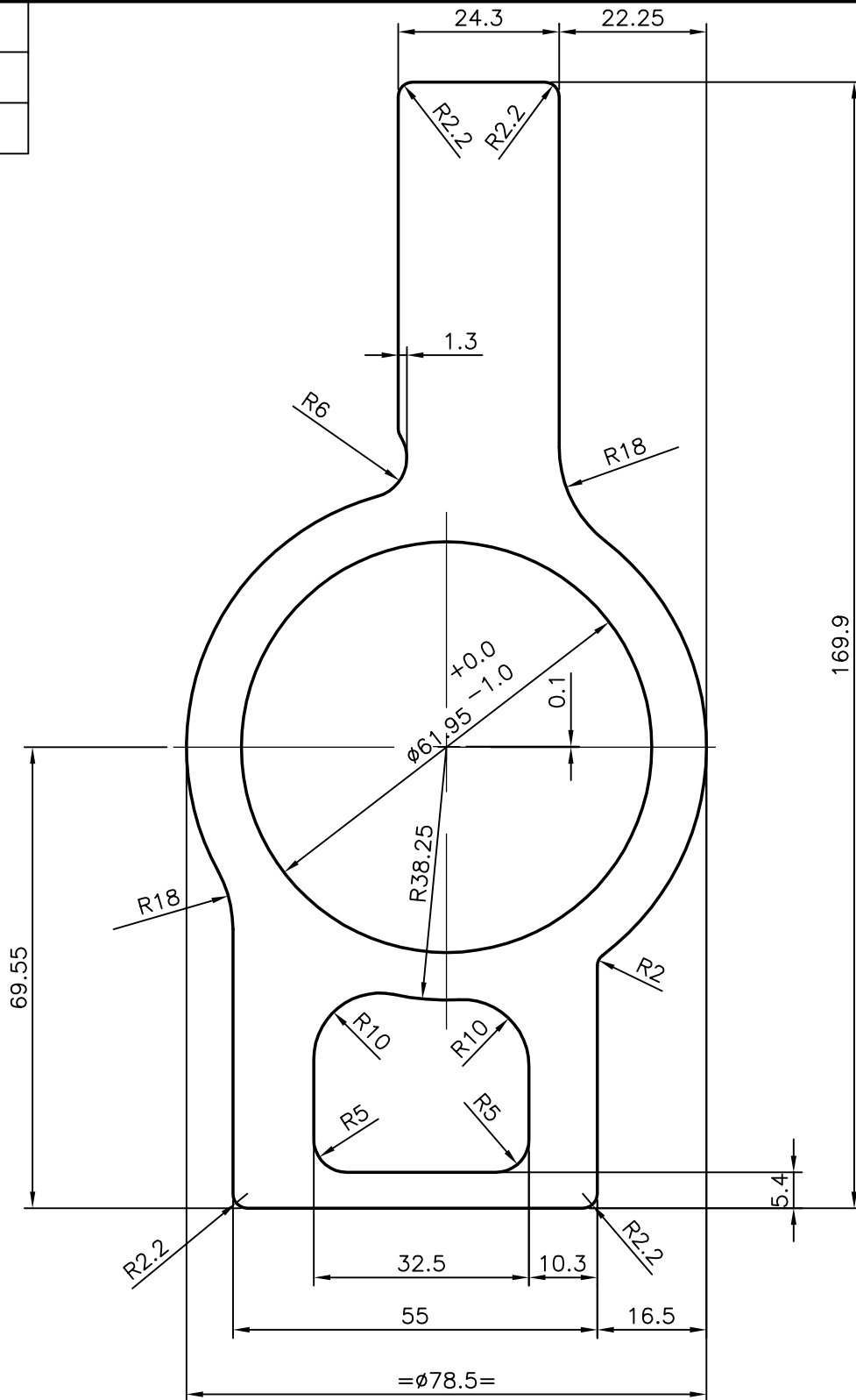

JINDAL ALUMINIUM LTD.
BANGALORE-560073 (INDIA)

	NAME	DATE
DRAWN	J.P.KAUSHIK	22-08-2006
CHECKED		
APPROVED		

1. ALL DIMENSIONS ARE IN mm.
2. ROUND OFF ALL SHARP CORNERS WITH 0.40 mm.
3. TOLERANCES WILL BE AS PER IS:6477-1983 UNLESS OTHERWISE SPECIFIED

SCALE	1:1
AREA mm ²	4414.79
PERIMETER mm.	444.272
WEIGHT kg/m	11.92

PARTY'S NAME	STORK RUBBER PRODUCTS (P) LTD., GURGAON
PARTY'S DRAWING No.	SRPL 1928 (PART No 10-2698)
ALLOY & TEMPER	6082 T6
DESCRIPTION	MISC. SECION

DRAWING No.	SECTION No.
P-6623	-
S1851	S1851
29311	29311