

P-7961
X784
29330

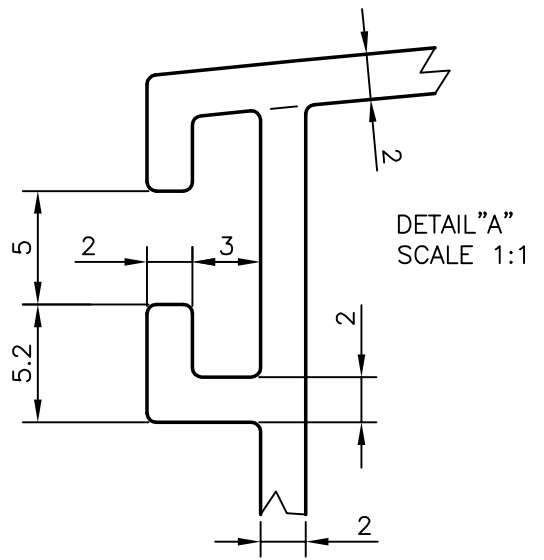

F = FULL RADIUS (8 PLACES)

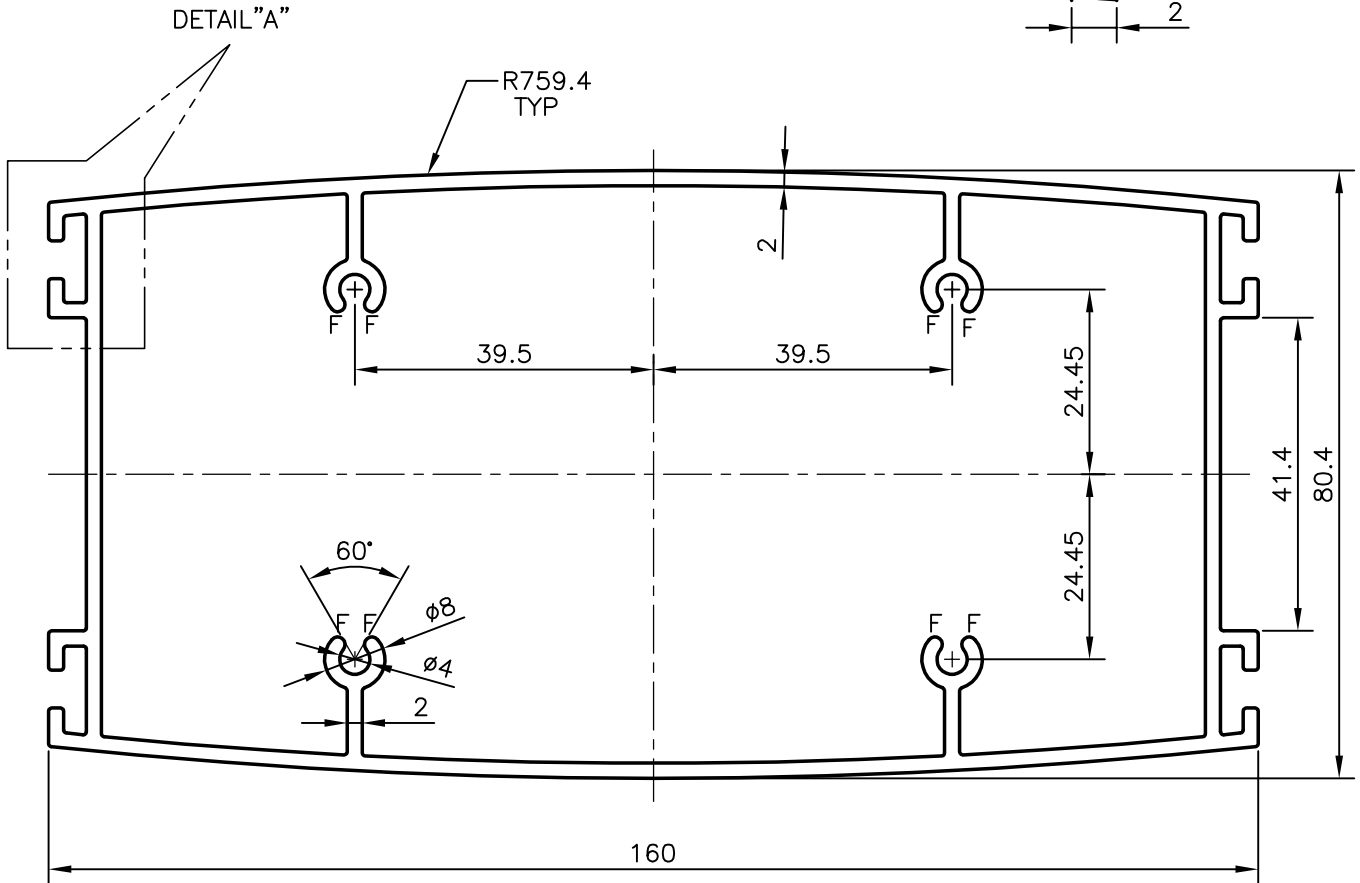

SYMBOL OF QUALITY
AN ISO 9001 COMPANY

JINDAL ALUMINIUM LTD.
BANGALORE-560073 (INDIA)

	NAME	DATE
DRAWN	RAGHAVENDRA	28-02-2008
CHECKED		
APPROVED		

1. ALL DIMENSIONS ARE IN mm.
2. ROUND OFF ALL SHARP CORNERS WITH 0.40 mm.
3. TOLERANCES WILL BE AS PER IS:6477-1983 UNLESS OTHERWISE SPECIFIED

SCALE	1:1
AREA mm ²	1201.172
PERIMETER mm.	570.126
WEIGHT kg/m	3.243

PARTY'S NAME	ADVANCE DECOR INDIA PVT. LTD., NEW DELHI	DRAWING No.	P-7961	SECTION No.	-
PARTY'S DRAWING No.	AS PER DRAWING	X784	X784		
ALLOY & TEMPER	HE9 WP	29330	29330		
DESCRIPTION	MISC. SECTION				