

P-9106-1

29339

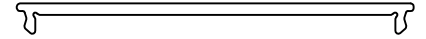

1:1

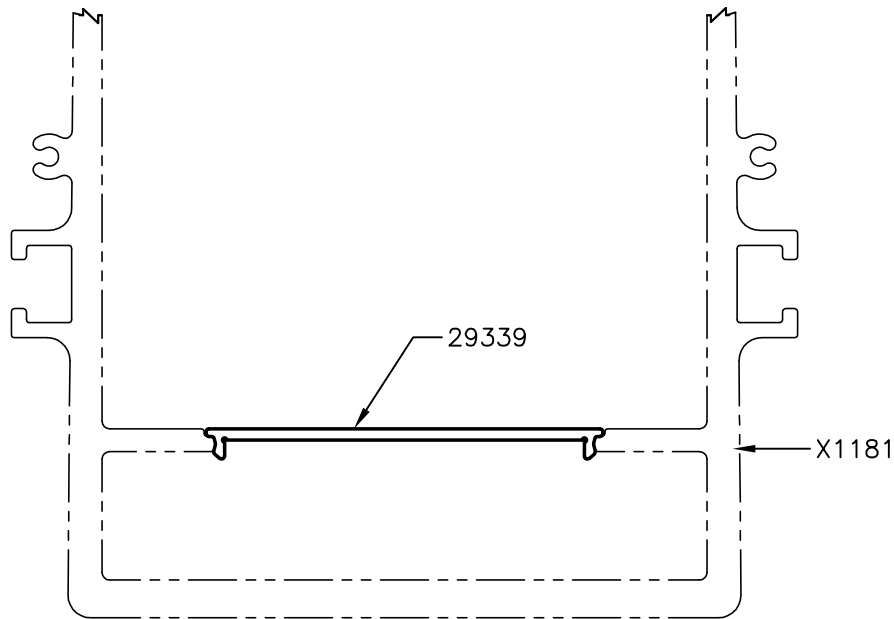
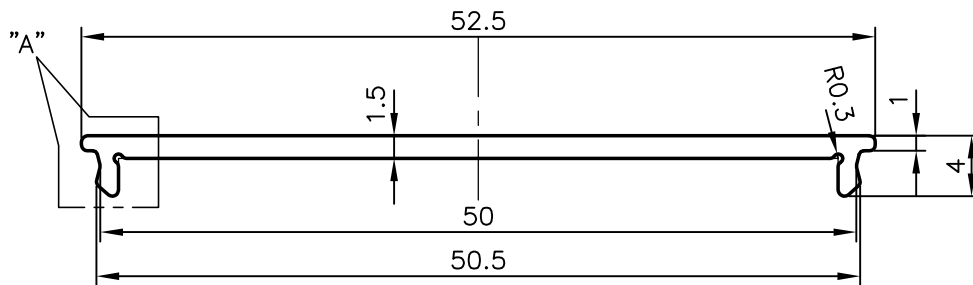
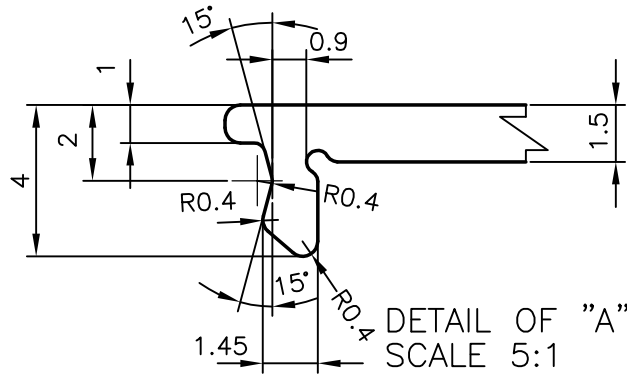

SYMBOL OF QUALITY
AN ISO 9001 COMPANY

JINDAL ALUMINIUM LTD.
BANGALORE-560073 (INDIA)

	NAME	DATE
DRAWN	J.P.KAUSHIK	10-03-2009
CHECKED		
APPROVED		

1. ALL DIMENSIONS ARE IN mm.
2. ROUND OFF ALL SHARP CORNERS WITH 0.40 mm.
3. TOLERANCES WILL BE AS PER BS:EN-755 UNLESS OTHERWISE SPECIFIED

SCALE	2:1
AREA mm ²	83.155
PERIMETER mm.	117.535
WEIGHT kg/m	0.225

PARTY'S NAME	BADER AL-MULLA & BROS., KUWAIT
PARTY'S DRAWING No.	AS PER SPECIFICATION
ALLOY & TEMPER	6063 T6
DESCRIPTION	MISC. SECTION

DRAWING No.	SECTION No.
P-9106-1	-
29339	29339