

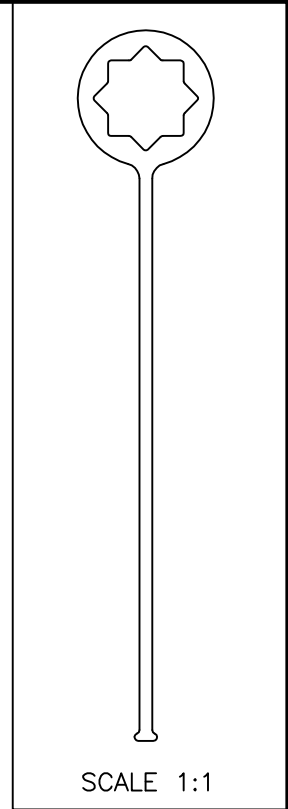

P-7102
S1965
29340

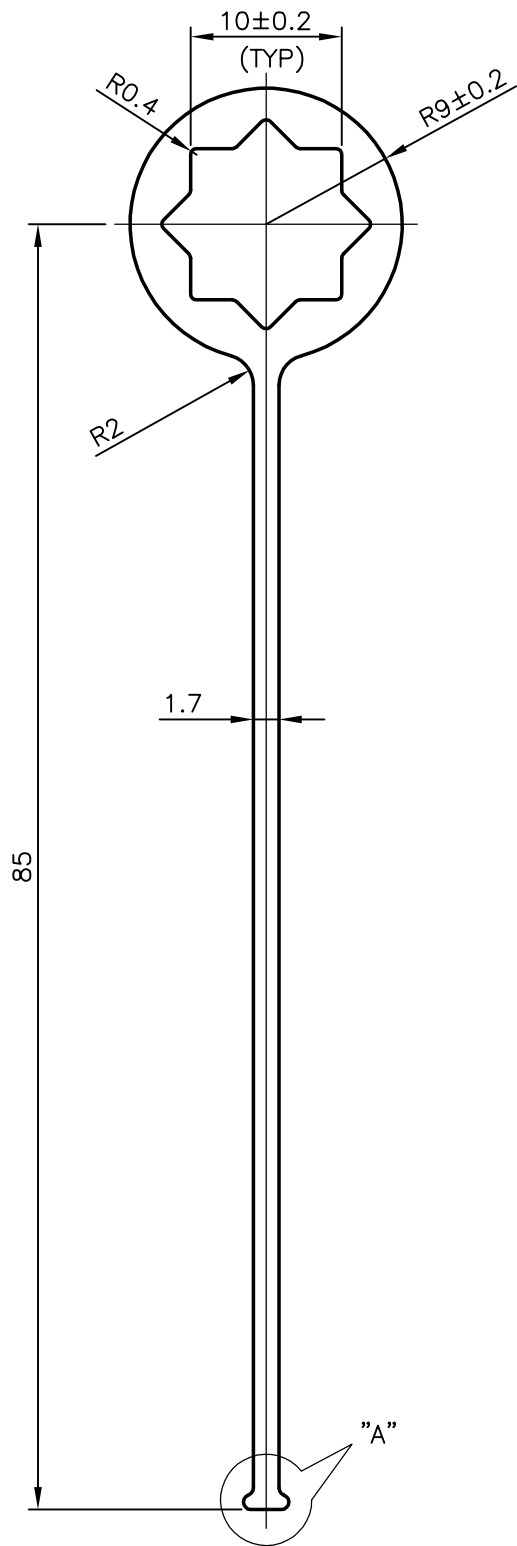
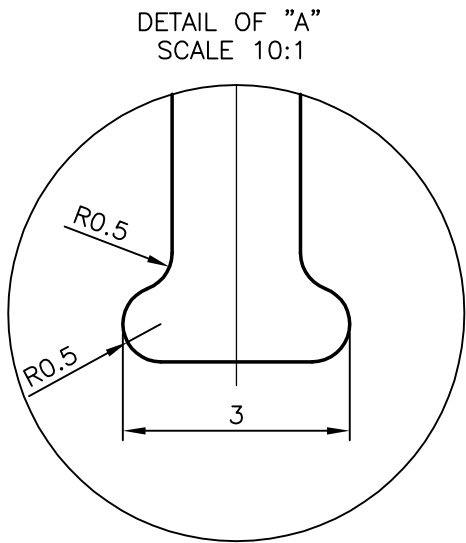

NOTE:-  
1. PART SHALL BE CLEAN AND FREE OF CONTAMINANTS

 SYMBOL OF QUALITY AN ISO 9001 COMPANY	<b>JINDAL ALUMINIUM LTD.</b> BANGALORE-560073 (INDIA)	NAME		DATE
		DRAWN	PRASANN.H	10-03-2007
1. ALL DIMENSIONS ARE IN mm. 2. ROUND OFF ALL SHARP CORNERS WITH 0.40 mm. 3. TOLERANCES WILL BE AS PER IS:6477-1983 UNLESS OTHERWISE SPECIFIED		CHECKED		
		APPROVED		
PARTY'S NAME PRESSTON ENGINEERING CORPORATION, BANGALORE		SCALE		2:1
		AREA mm <sup>2</sup>		268.965
PARTY'S DRAWING No. CRAL17BAEV01		PERIMETER mm.		208.941
		WEIGHT kg/m		0.726
ALLOY & TEMPER HE9 WP		DRAWING No.		P-7102
		SECTION No.		-
DESCRIPTION BAFFLE EVAP		S1965		S1965
		29340		29340