

P-6781
S1981
29344

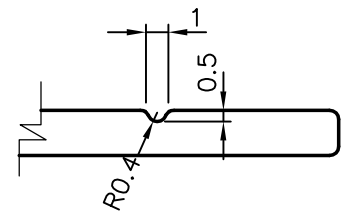
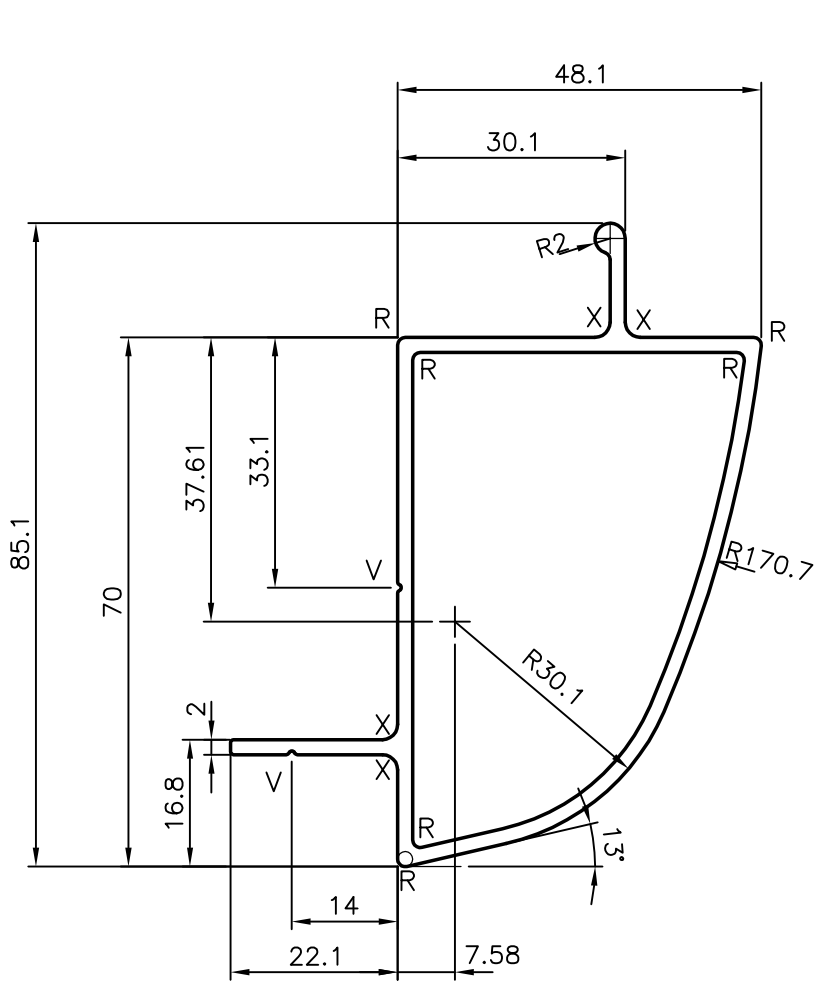

VEE GROOVE DETAIL

R = 1.0 RADIUS (6 PLACES)

X = 2.0 RADIUS (4 PLACES)

GENERAL WALL THICKNESS 2.0



SYMBOL OF QUALITY
AN ISO 9001 COMPANY

JINDAL ALUMINIUM LTD.
BANGALORE-560073 (INDIA)

	NAME	DATE
DRAWN	J.P.KAUSHIK	31-10-2006
CHECKED		
APPROVED		
SCALE		1:1
AREA mm ²		490.931
PERIMETER mm.		284.559
WEIGHT kg/m		1.326
DRAWING No.	SECTION No.	
P-6781	-	
S1981	S1981	
29344	29344	

1. ALL DIMENSIONS ARE IN mm.
2. ROUND OFF ALL SHARP CORNERS WITH 0.40 mm.
3. TOLERANCES WILL BE AS PER IS:6477-1983 UNLESS OTHERWISE SPECIFIED

PARTY'S NAME	AVASARALA TECHNOLOGIES LTD., BANGALORE
PARTY'S DRAWING No.	A70314
ALLOY & TEMPER	HE9 WP
DESCRIPTION	UPRIGHT 3 / RR