

P-7339-2

S2014

29359

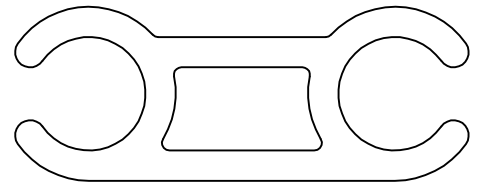

SCALE 1:1

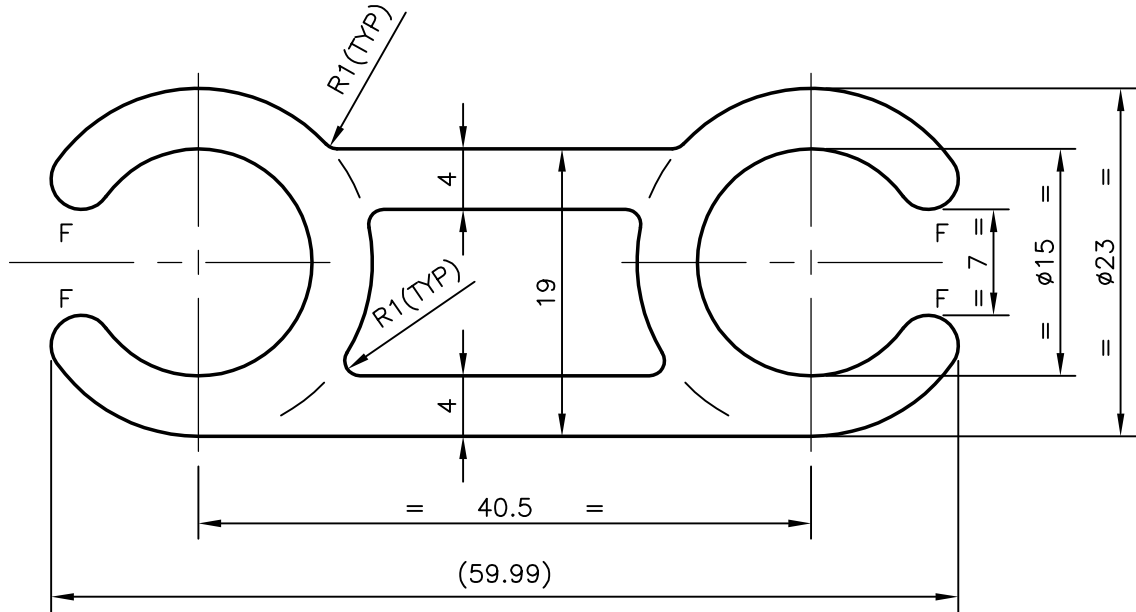

NOTE:-

- 1. F = FULL RADIUS (4 PLACES)



SYMBOL OF QUALITY
AN ISO 9001 COMPANY

JINDAL ALUMINIUM LTD.
BANGALORE-560073 (INDIA)

	NAME	DATE
DRAWN	PRASANN.H	03-07-2007
CHECKED		
APPROVED		

- 1. ALL DIMENSIONS ARE IN mm.
- 2. ROUND OFF ALL SHARP CORNERS WITH 0.40 mm.
- 3. TOLERANCES WILL BE AS PER IS:6477-1983 UNLESS OTHERWISE SPECIFIED

SCALE	2:1
AREA mm ²	606.708
PERIMETER mm.	227.957
WEIGHT kg/m	1.638

PARTY'S NAME	POLYKLAD STRUCTURALS PVT. LTD., BANGALORE
PARTY'S DRAWING No.	PSPL/41/001/2
ALLOY & TEMPER	HE9 WP
DESCRIPTION	MISC. PROFILE

DRAWING No.	SECTION No.
P-7339-2	-
S2014	S2014
29359	29359