

P-7336-2

X708

29376

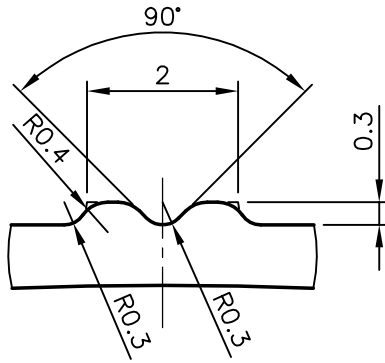
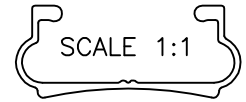

DETAIL OF "A"
SCALE:-10:1

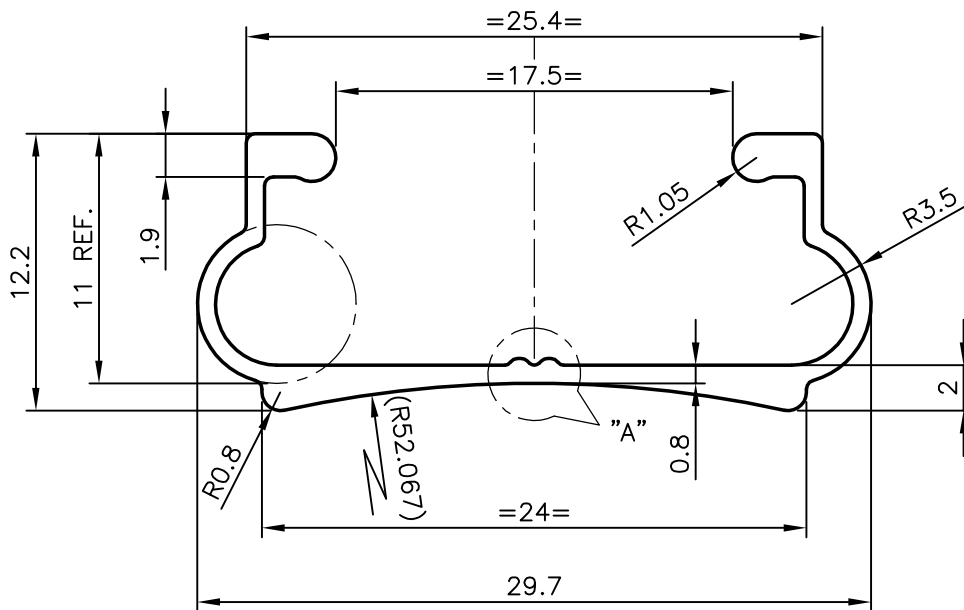

NOTE:-

- 1. UNSPECIFIED WALL THICKNESS:- 0.80 mm



SYMBOL OF QUALITY
AN ISO 9001 COMPANY

JINDAL ALUMINIUM LTD.
BANGALORE-560073 (INDIA)

	NAME	DATE
DRAWN	J.P.KAUSHIK	19-06-2007
CHECKED		
APPROVED		

- 1. ALL DIMENSIONS ARE IN mm.
- 2. ROUND OFF ALL SHARP CORNERS WITH 0.40 mm.
- 3. TOLERANCES WILL BE AS PER IS:3965-1981 UNLESS OTHERWISE SPECIFIED

SCALE	3:1
AREA mm ²	62.297
PERIMETER mm.	112.81
WEIGHT kg/m	0.168

PARTY'S NAME	GREEN HOUSE SOLUTION, BANGALORE
PARTY'S DRAWING No.	AS PER SECTION No X683 & REQUIREMENT
ALLOY & TEMPER	HE9 WP
DESCRIPTION	MISC. CHANNEL

DRAWING No.	SECTION No.
P-7336-2	-
X708	X708
29376	29376