

P-9266-2

S2164

29384

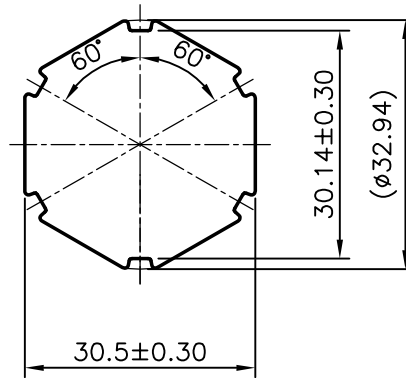
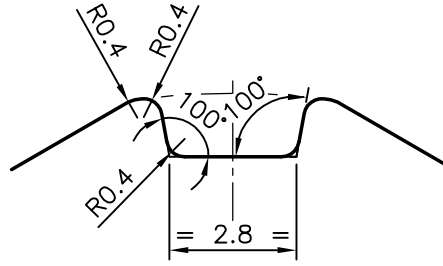

SYMBOL OF QUALITY
AN ISO 9001 COMPANY

JINDAL ALUMINIUM LTD.
BANGALORE-560073 (INDIA)

	NAME	DATE
DRAWN	J.P.KAUSHIK	19-06-2009
CHECKED		
APPROVED		
SCALE		1:1
AREA mm ²		765.862
PERIMETER mm.		111.68
WEIGHT kg/m		2.068
DRAWING No.	SECTION No.	
P-9266-2	-	
S2164	S2164	
29384	29384	

1. ALL DIMENSIONS ARE IN mm.
2. ROUND OFF ALL SHARP CORNERS WITH 0.40 mm.
3. TOLERANCES WILL BE AS PER IS:3965-1981 UNLESS OTHERWISE SPECIFIED

PARTY'S NAME	BRITISH ENGINES INDIA PVT. LTD., BANGALORE
PARTY'S DRAWING No.	20sTMC2/TMC2X EXTRUSION
ALLOY & TEMPER	6082 T6
DESCRIPTION	HEXAGONAL BAR