

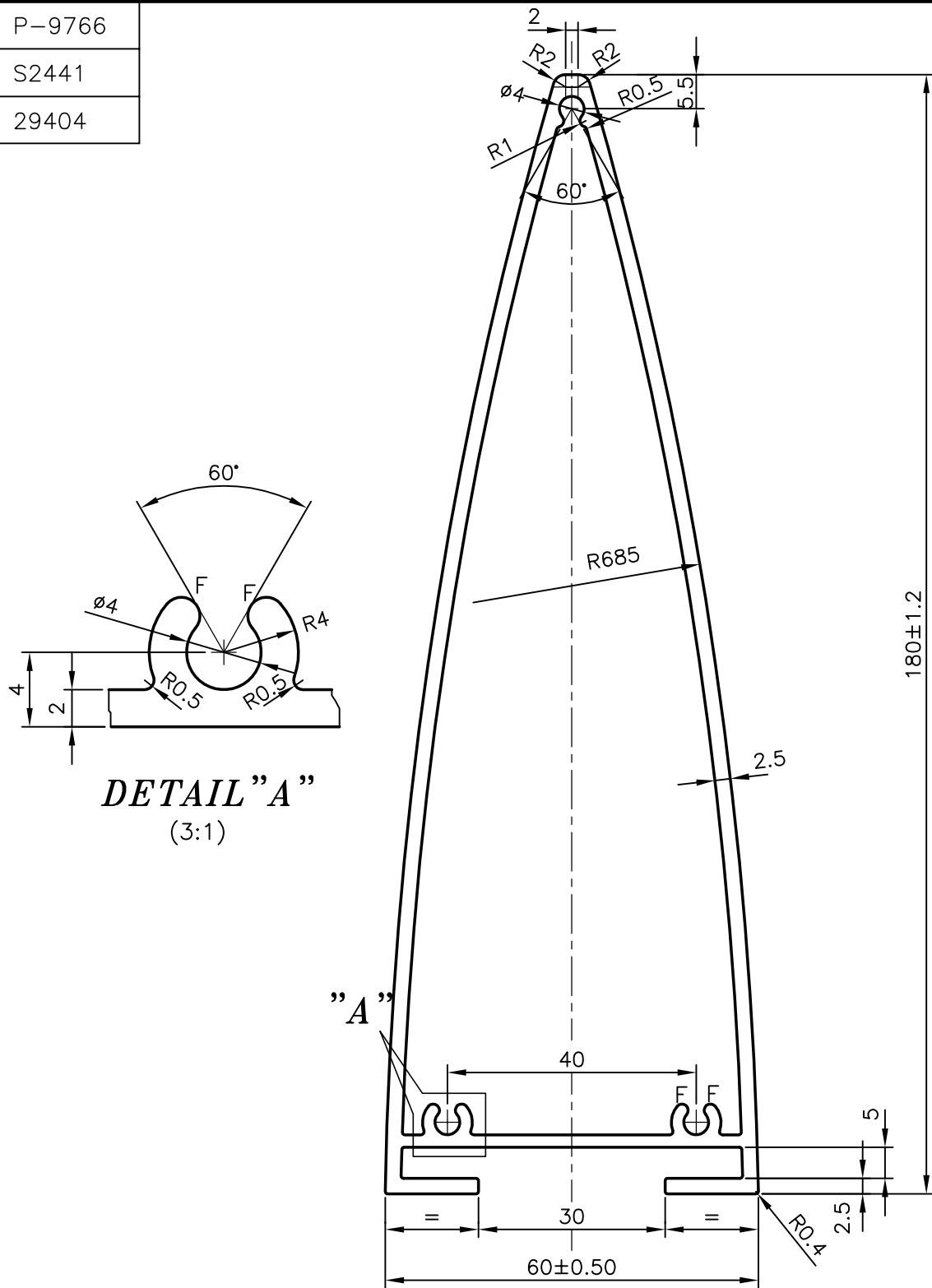

P-9766  
S2441  
29404



**DETAIL "A"**  
(3:1)

F = FULL RADIUS ( 4 PLACES)

 SYMBOL OF QUALITY AN ISO 9001 COMPANY	<b>JINDAL ALUMINIUM LTD.</b> BANGALORE-560073 (INDIA)	NAME	DATE
		DRAWN	J.P.KAUSHIK 27-01-2010
		CHECKED	
1. ALL DIMENSIONS ARE IN mm. 2. ROUND OFF ALL SHARP CORNERS WITH 0.40 mm. 3. TOLERANCES WILL BE AS PER IS:6477-1983, UNLESS OTHERWISE SPECIFIED		APPROVED	
		SCALE	1:1
		AREA mm <sup>2</sup>	1128.853
PARTY'S NAME		PERIMETER mm.	492.268
		WEIGHT kg/m	3.048
PARTY'S DRAWING No.		DRAWING No.	SECTION No.
		P-9766	-
ALLOY & TEMPER		S2441	S2441
		29404	29404
DESCRIPTION			
LOUVER-360 SECTION			