

P-10472

29411

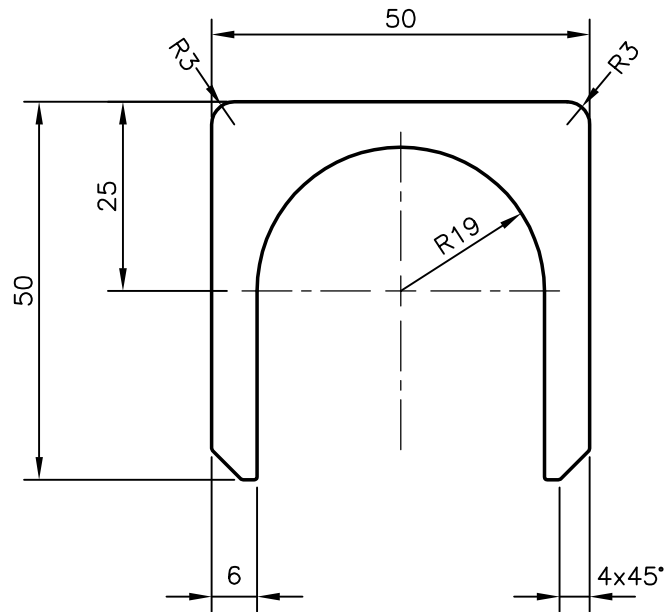

SYMBOL OF QUALITY
AN ISO 9001 COMPANY

JINDAL ALUMINIUM LTD.
BANGALORE-560073 (INDIA)

	NAME	DATE
DRAWN	J.P.KAUSHIK	07-10-2010
CHECKED		
APPROVED	S.S.GARG	25-10-2010
SCALE		1:1
AREA mm ²		962.997
PERIMETER mm.		264.017
WEIGHT kg/m		2.6
DRAWING No.	SECTION No.	
P-10472	-	
29411	29411	

1. ALL DIMENSIONS ARE IN mm.
2. ROUND OFF ALL SHARP CORNERS WITH 0.40 mm.
3. TOLERANCES WILL BE AS PER,BS:EN-755 UNLESS OTHERWISE SPECIFIED

PARTY'S NAME	DOLPHIN MANUFACTURING LTD., (L.L.C.) AJMAN-UAE
PARTY'S DRAWING No.	EXT-50X50
ALLOY & TEMPER	6060 T5
DESCRIPTION	CHANNEL-MISCELLANEOUS