

P-9270-1

S2168

29430

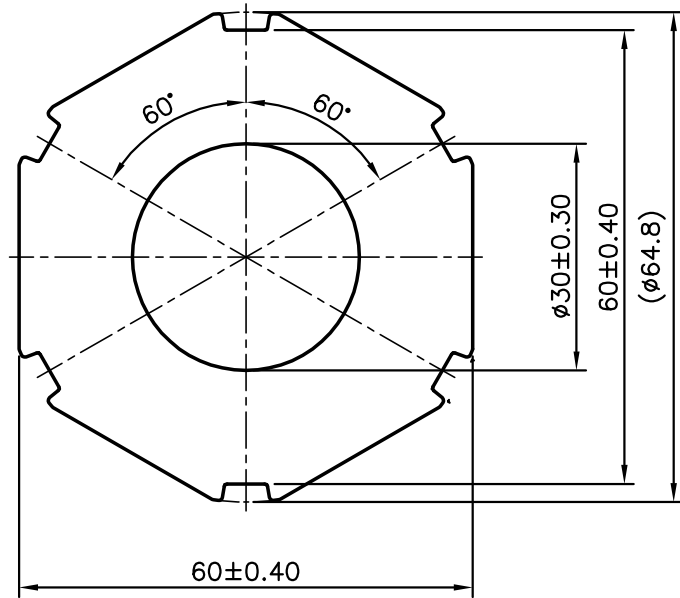
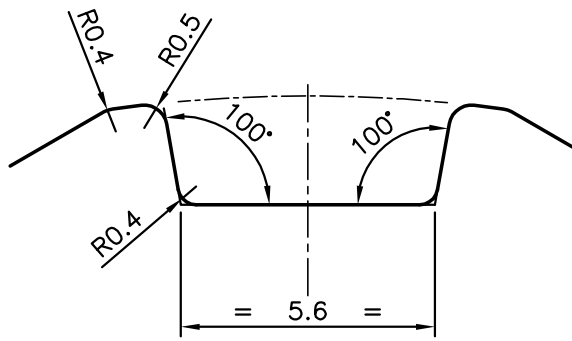

SYMBOL OF QUALITY
AN ISO 9001 COMPANY

JINDAL ALUMINIUM LTD.
BANGALORE-560073 (INDIA)

	NAME	DATE
DRAWN	J.P.KAUSHIK	19-06-2009
CHECKED		
APPROVED		

1. ALL DIMENSIONS ARE IN mm.
2. ROUND OFF ALL SHARP CORNERS WITH 0.40 mm.
3. TOLERANCES WILL BE AS PER IS:6477-1983 UNLESS OTHERWISE SPECIFIED

SCALE	1:1
AREA mm ²	2269.321
PERIMETER mm.	218.777
WEIGHT kg/m	6.127

PARTY'S NAME	BRITISH ENGINES INDIA PVT. LTD., BANGALORE
PARTY'S DRAWING No.	40sTMC2/TMC2X EXTRUSION
ALLOY & TEMPER	6082 T6
DESCRIPTION	HEXAGONAL TUBE

DRAWING No.	SECTION No.
P-9270-1	-
S2168	S2168
29430	29430