

P-9303-2

S2187

29449

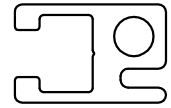

1:1

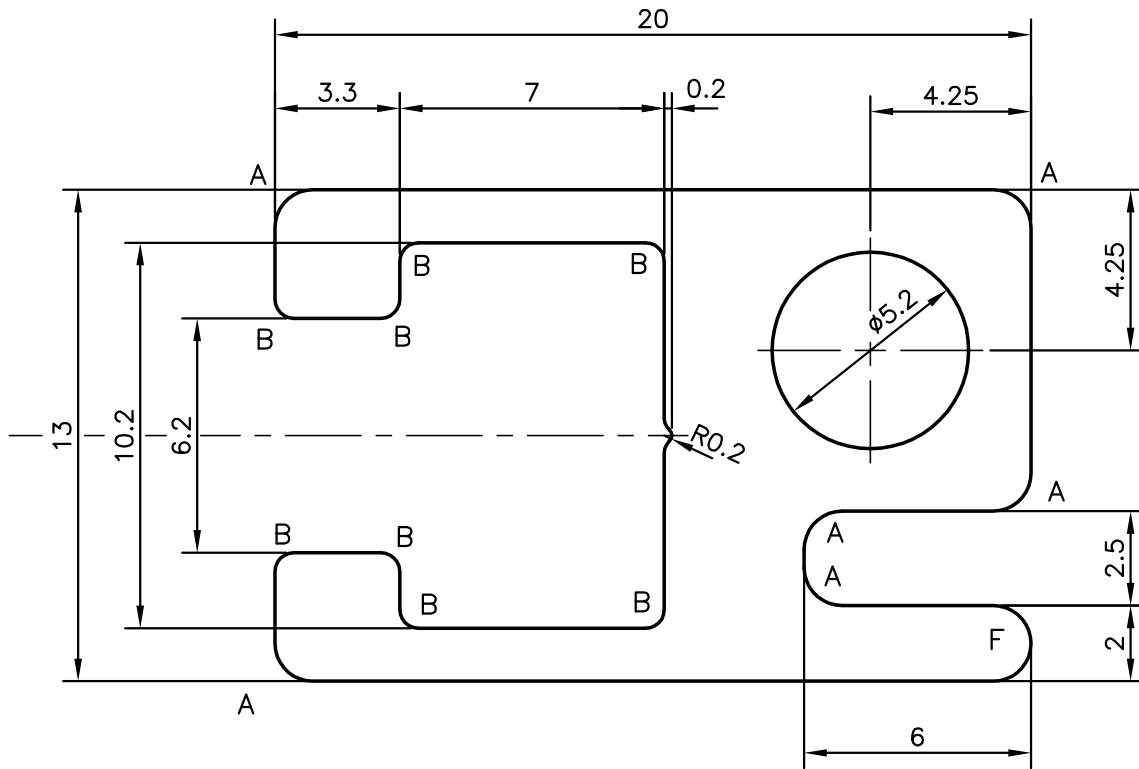

A = 1.0 RADIUS (6 PLACES)

B = 0.5 RADIUS (8 PLACES)

F = FULL RADIUS (1 PLACE)



SYMBOL OF QUALITY
AN ISO 9001 COMPANY

JINDAL ALUMINIUM LTD.
BANGALORE-560073 (INDIA)

	NAME	DATE
DRAWN	J.P.KAUSHIK	27-06-2009
CHECKED		
APPROVED		

1. ALL DIMENSIONS ARE IN mm.
2. ROUND OFF ALL SHARP CORNERS WITH 0.50 mm.
3. TOLERANCES WILL BE AS PER IS:6477-1983 UNLESS OTHERWISE SPECIFIED

SCALE	5:1
AREA mm ²	130.966
PERIMETER mm.	101.564
WEIGHT kg/m	0.354

PARTY'S NAME	HERO PRODUCTS, MUMBAI
--------------	-----------------------

PARTY'S DRAWING No.	HERO 003
---------------------	----------

ALLOY & TEMPER	HE9 WP
----------------	--------

DESCRIPTION	MISCELLANEOUS SECTION-HOLLOW
-------------	------------------------------

DRAWING No.	SECTION No.
P-9303-2	-
S2187	S2187
29449	29449