

P-9411

X1197

29450

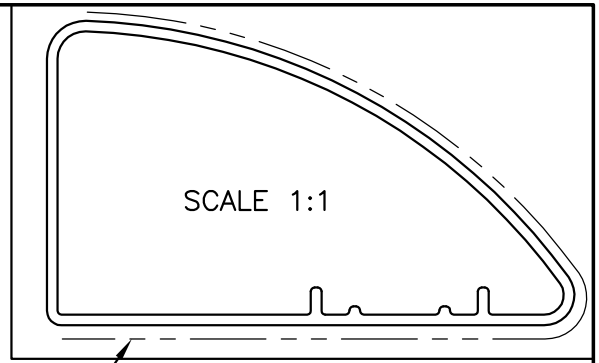

SCALE 1:1

EXPOSED SURFACE

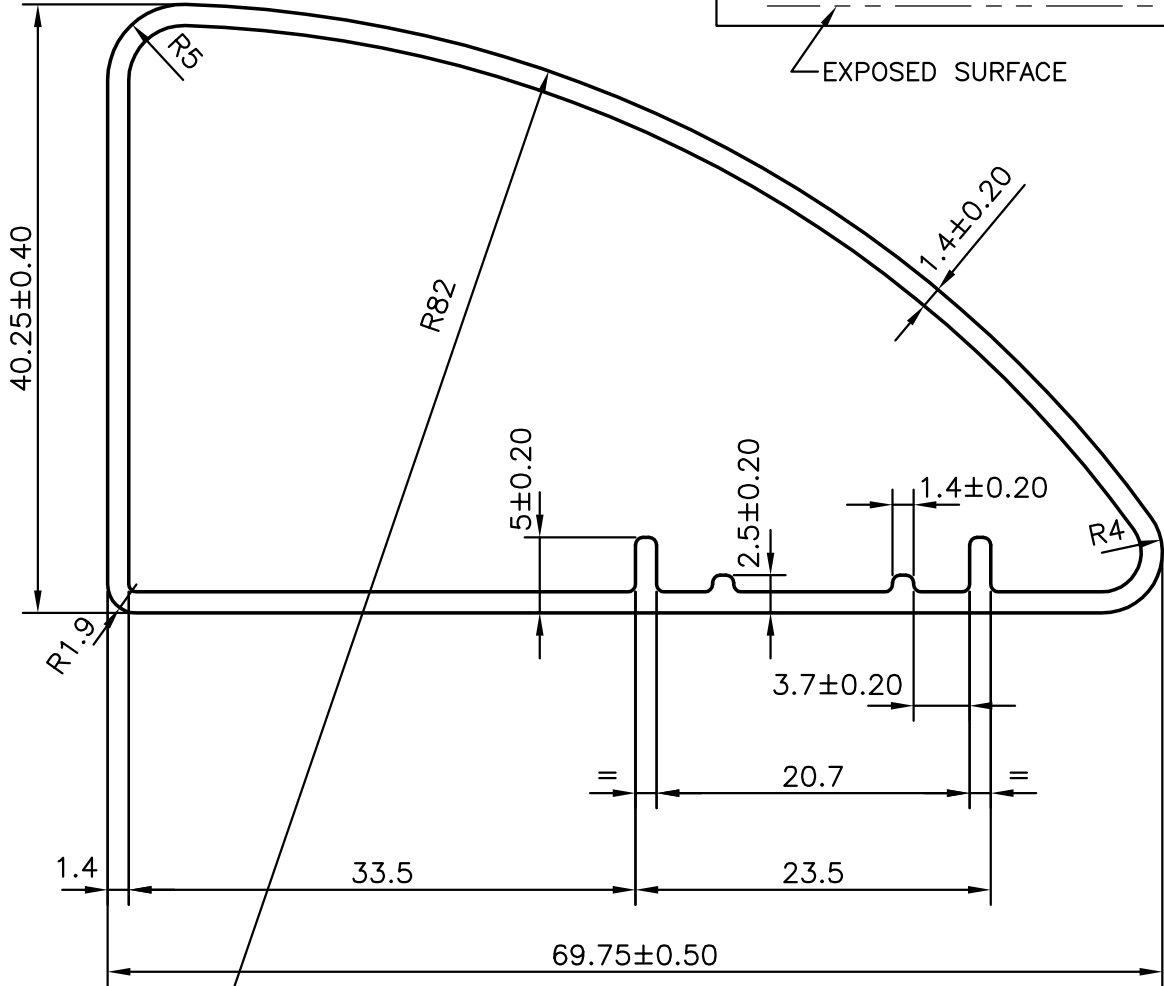

1. UNSPECIFIED WALL THICKNESS:- 1.40 mm.±0.20
2. UNSPECIFIED RADII:- 0.50 mm.



SYMBOL OF QUALITY
AN ISO 9001 COMPANY

JINDAL ALUMINIUM LTD.
BANGALORE-560073 (INDIA)

	NAME	DATE
DRAWN	RAGHAVENDRA	23-07-2009
CHECKED		
APPROVED		

1. ALL DIMENSIONS ARE IN mm.
2. ROUND OFF ALL SHARP CORNERS WITH 0.50 mm.
3. TOLERANCES WILL BE AS PER IS:6477-1983 UNLESS OTHERWISE SPECIFIED

SCALE	2:1
AREA mm ²	275.57
PERIMETER mm.	191.834
WEIGHT kg/m	0.744

PARTY'S NAME TEAM CONCEPTS PVT. LTD., BANGALORE

DRAWING No. SECTION No.

PARTY'S DRAWING No. TRCAL02

P-9411

-

ALLOY & TEMPER 63400 WP

X1197

X1197

29450

29450

DESCRIPTION

MISC. TUBE - RC - REAR SECTION