

P-9479

X1210

29457

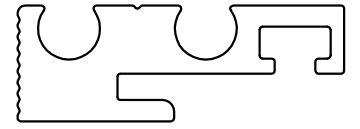

1:1

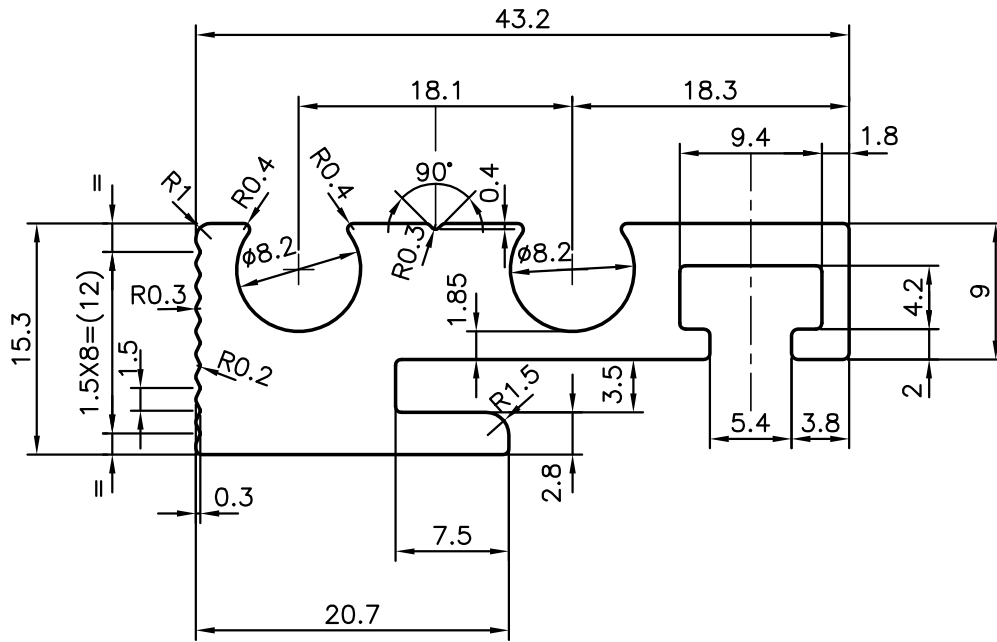
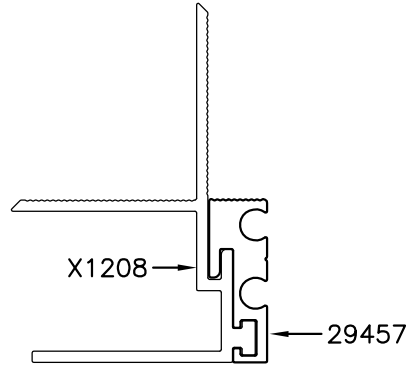

SYMBOL OF QUALITY
AN ISO 9001 COMPANY

JINDAL ALUMINIUM LTD.
BANGALORE-560073 (INDIA)

	NAME	DATE
DRAWN	J.P.KAUSHIK	17-09-2009
CHECKED		
APPROVED		

1. ALL DIMENSIONS ARE IN mm.
2. ROUND OFF ALL SHARP CORNERS WITH 0.40 mm.
3. TOLERANCES WILL BE AS PER IS:3965-1981 UNLESS OTHERWISE SPECIFIED

SCALE	2:1
AREA mm ²	341.312
PERIMETER mm.	175.396
WEIGHT kg/m	0.922

PARTY'S NAME V.G.SALES, NEW DELHI

PARTY'S DRAWING No. AS PER SAMPLE 3B

ALLOY & TEMPER HE9 WP

DESCRIPTION MISC. SECTION

DRAWING No.	SECTION No.
P-9479	-
X1210	X1210
29457	29457