

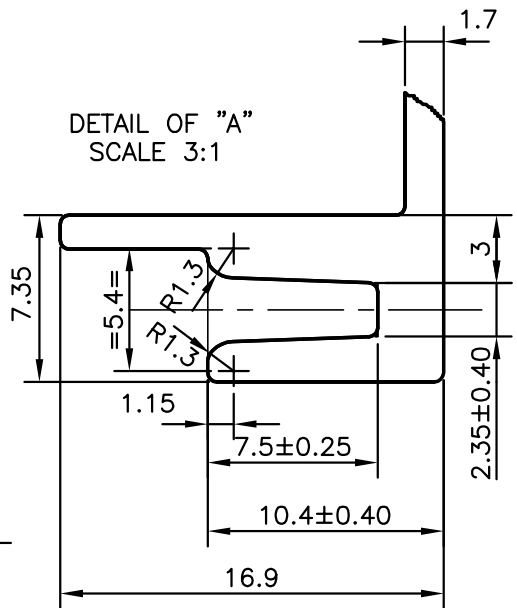

P-10118
S2564
29474

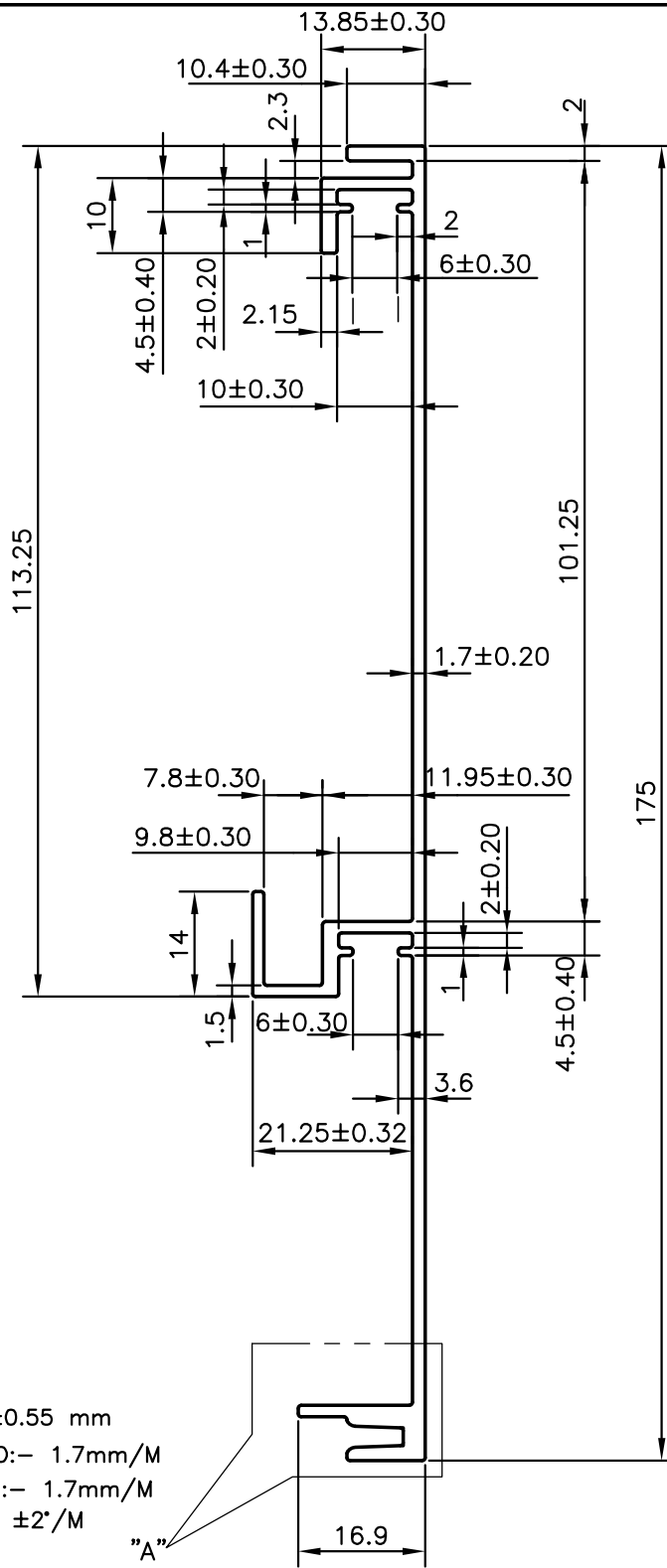

- 1 FLATNESS:-  $\pm 0.55$  mm
- 2 TWIST & BAND:- 1.7mm/M
- 3 STRAIGHTNESS:- 1.7mm/M
- 3 ANGULARITY:-  $\pm 2^\circ$ /M

"A"

 SYMBOL OF QUALITY AN ISO 9001 COMPANY	<b>JINDAL ALUMINIUM LTD.</b> BANGALORE-560073 (INDIA)	NAME	DATE	
		DRAWN	J.P.KAUSHIK	21-06-2010
		CHECKED		
		APPROVED	S.S.GARG	28-06-2010
1. ALL DIMENSIONS ARE IN mm. 2. ROUND OFF ALL SHARP CORNERS WITH 0.40 mm. 3. TOLERANCES WILL BE AS PER DIN EN 12020 UNLESS OTHERWISE SPECIFIED		SCALE	1:1	
		AREA mm <sup>2</sup>	481.694	
		PERIMETER mm.	548.756	
PARTY'S NAME	AAF INDIA PVT.LTD., BANGALORE	WEIGHT kg/m	1.301	
PARTY'S DRAWING No.	AAF-RD-EXT 035	DRAWING No.	SECTION No.	
ALLOY & TEMPER	HE9 WP	P-10118	-	
DESCRIPTION	MISC. SECTION	S2564	S2564	
		29474	29474	