

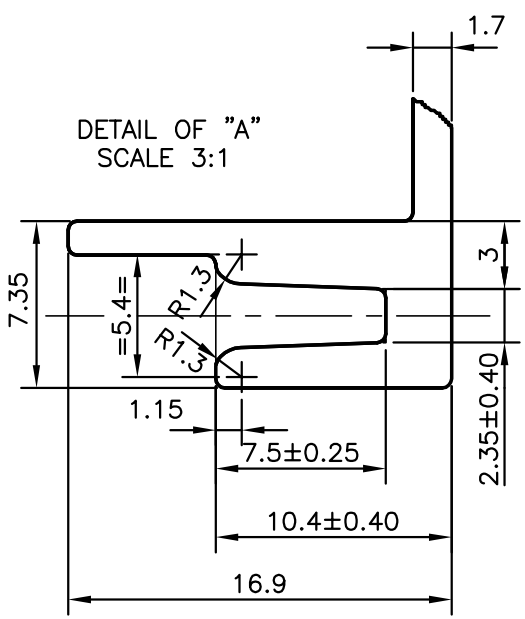

P-10122
S2566
29477

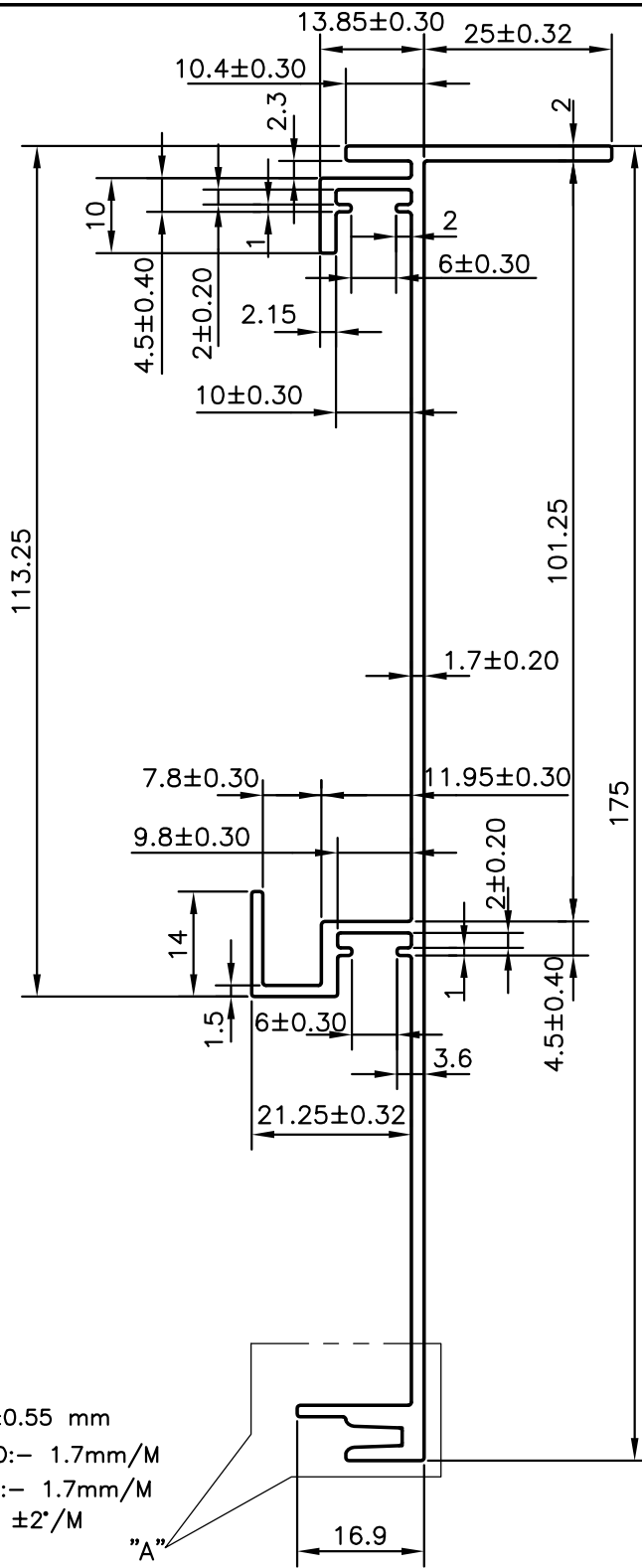

- 1 FLATNESS:- ±0.55 mm
- 2 TWIST & BAND:- 1.7mm/M
- 3 STRAIGHTNESS:- 1.7mm/M
- 3 ANGULARITY:- ±2°/M

"A"

 SYMBOL OF QUALITY AN ISO 9001 COMPANY	<b>JINDAL ALUMINIUM LTD.</b> BANGALORE-560073 (INDIA)	NAME	DATE
		DRAWN	J.P.KAUSHIK
		CHECKED	
		APPROVED	S.S.GARG
		SCALE	1:1
		AREA mm <sup>2</sup>	531.694
		PERIMETER mm.	598.413
		WEIGHT kg/m	1.436
PARTY'S NAME	AAF INDIA PVT.LTD., BANGALORE	DRAWING No.	SECTION No.
PARTY'S DRAWING No.	AAF-RD-EXT 042	P-10122	-
ALLOY & TEMPER	HE9 WP	S2566	S2566
		29477	29477
DESCRIPTION	MISC. SECTION		

- 1. ALL DIMENSIONS ARE IN mm.
- 2. ROUND OFF ALL SHARP CORNERS WITH 0.40 mm.
- 3. TOLERANCES WILL BE AS PER DIN EN 12020 UNLESS OTHERWISE SPECIFIED