

P-10007

X1277

29478

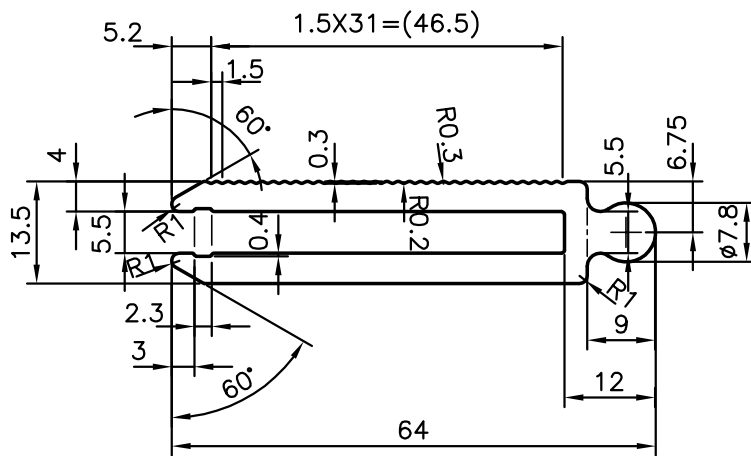
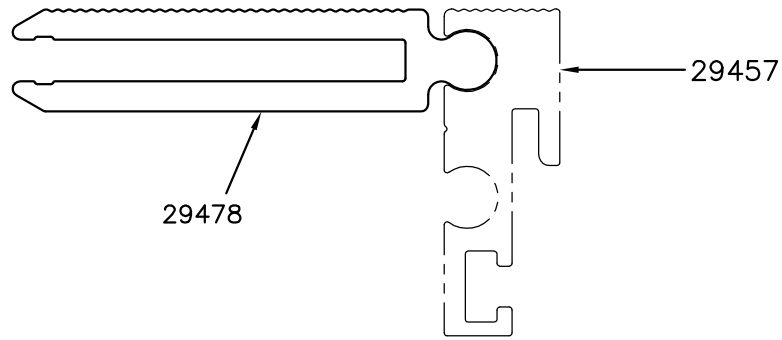

SYMBOL OF QUALITY  
AN ISO 9001 COMPANY

**JINDAL ALUMINIUM LTD.**  
BANGALORE-560073 (INDIA)

	NAME	DATE
DRAWN	J.P.KAUSHIK	06-05-2010
CHECKED		
APPROVED	S.S.GARG	18-05-2010

1. ALL DIMENSIONS ARE IN mm.
2. ROUND OFF ALL SHARP CORNERS WITH 0.40 mm.
3. TOLERANCES WILL BE AS PER IS:3965-1981 UNLESS OTHERWISE SPECIFIED

SCALE	1:1
AREA mm <sup>2</sup>	494.154
PERIMETER mm.	255.782
WEIGHT kg/m	1.334

PARTY'S NAME V.G. SALES, NEW DELHI

PARTY'S DRAWING No. AS PER SAMPLE 2A

ALLOY & TEMPER 6060 T6

DESCRIPTION MISC. SECTION

DRAWING No.	SECTION No.
P-10007	-
X1277	X1277
29478	29478