

P-10008

X1278

29479

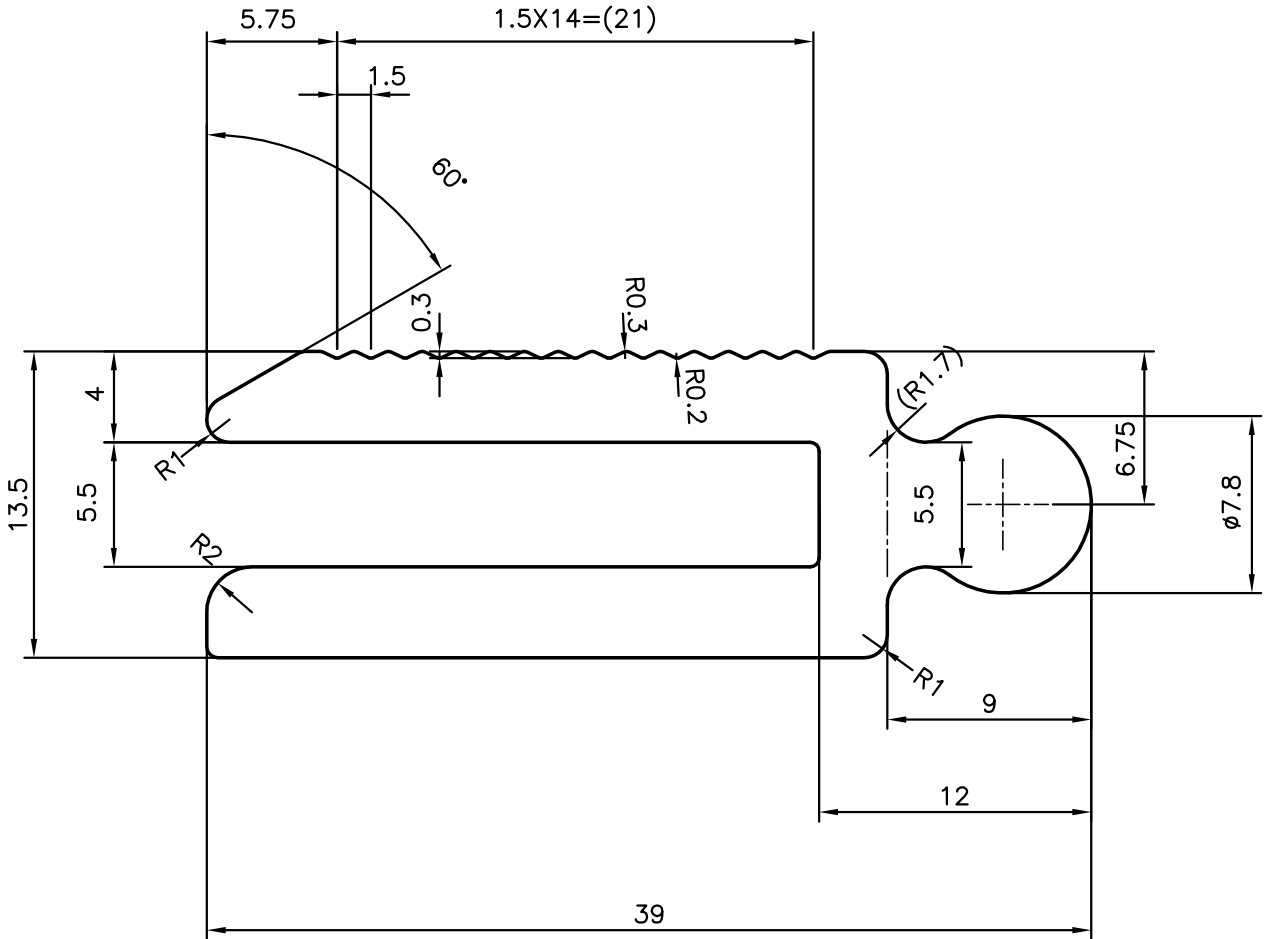
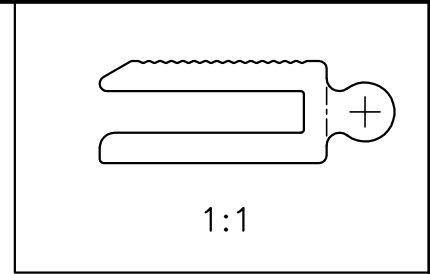
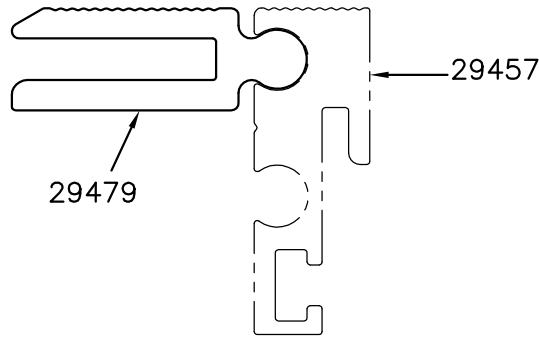

SYMBOL OF QUALITY
AN ISO 9001 COMPANY

JINDAL ALUMINIUM LTD.
BANGALORE-560073 (INDIA)

	NAME	DATE
DRAWN	J.P.KAUSHIK	06-05-2010
CHECKED		
APPROVED	S.S.GARG	18-05-2010
SCALE		3:1
AREA mm ²		302.378
PERIMETER mm.		155.003
WEIGHT kg/m		0.816

1. ALL DIMENSIONS ARE IN mm.
2. ROUND OFF ALL SHARP CORNERS WITH 0.40 mm.
3. TOLERANCES WILL BE AS PER IS:3965-1981 UNLESS OTHERWISE SPECIFIED

PARTY'S NAME	V.G. SALES, NEW DELHI	DRAWING No.	P-10008	SECTION No.	-
PARTY'S DRAWING No.	AS PER SAMPLE 1A	X1278	X1278		
ALLOY & TEMPER	6060 T6	29479	29479		
DESCRIPTION	MISC. SECTION				