

P-10056

X1297

29488

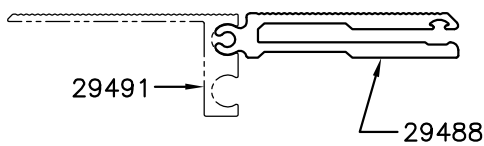
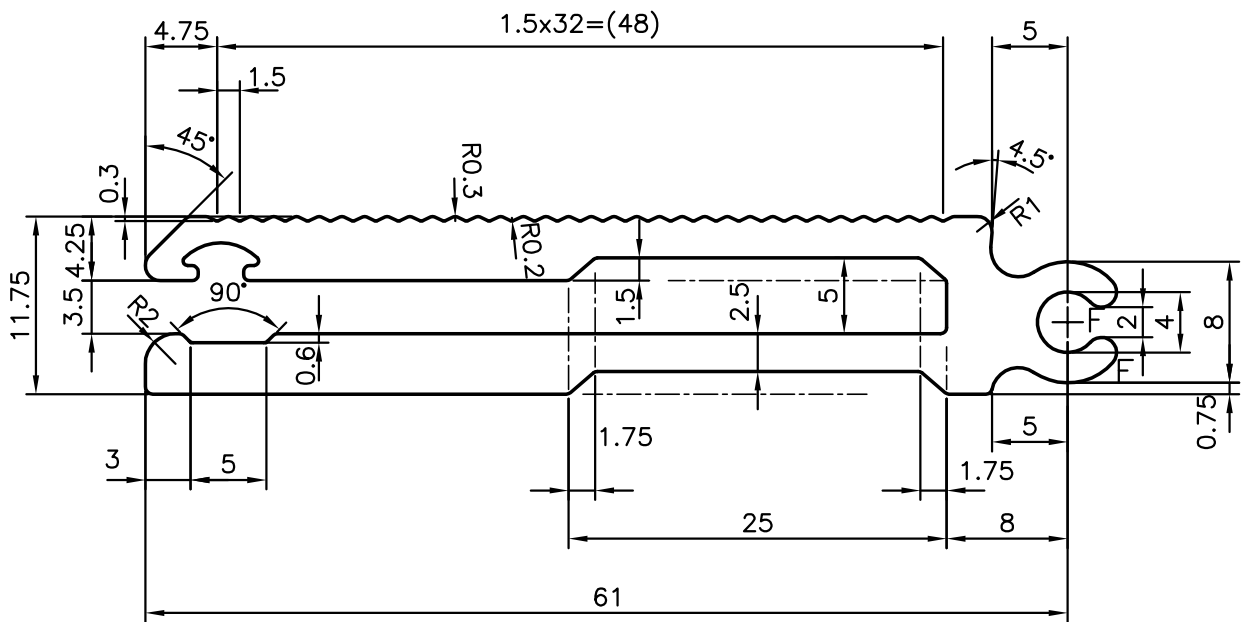
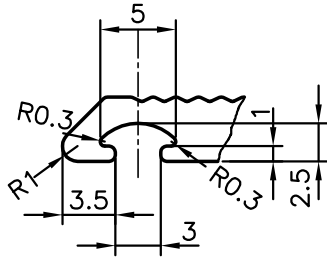
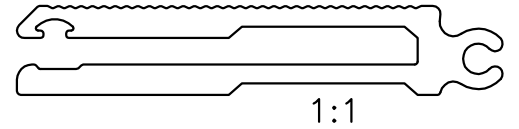

F = FULL RADIUS (2)



SYMBOL OF QUALITY
AN ISO 9001 COMPANY

JINDAL ALUMINIUM LTD.
BANGALORE-560073 (INDIA)

| | NAME | DATE |
|----------------------|-------------|------------|
| DRAWN | J.P.KAUSHIK | 21-05-2010 |
| CHECKED | | |
| APPROVED | S.S.GARG | 01-06-2010 |
| SCALE | | 2:1 |
| AREA mm ² | | 419.643 |
| PERIMETER mm. | | 276.337 |
| WEIGHT kg/m | | 1.133 |
| DRAWING No. | SECTION No. | |
| P-10056 | - | |
| X1297 | X1297 | |
| 29488 | 29488 | |

1. ALL DIMENSIONS ARE IN mm.
2. ROUND OFF ALL SHARP CORNERS WITH 0.40 mm.
3. TOLERANCES WILL BE AS PER IS:3965-1981 UNLESS OTHERWISE SPECIFIED

| | |
|---------------------|-----------------------|
| PARTY'S NAME | V.G. SALES, NEW DELHI |
| PARTY'S DRAWING No. | AS PER DRAWING (7F) |
| ALLOY & TEMPER | 6060 T6 |
| DESCRIPTION | MISC. SECTION |