

P-10117

S2563

29500

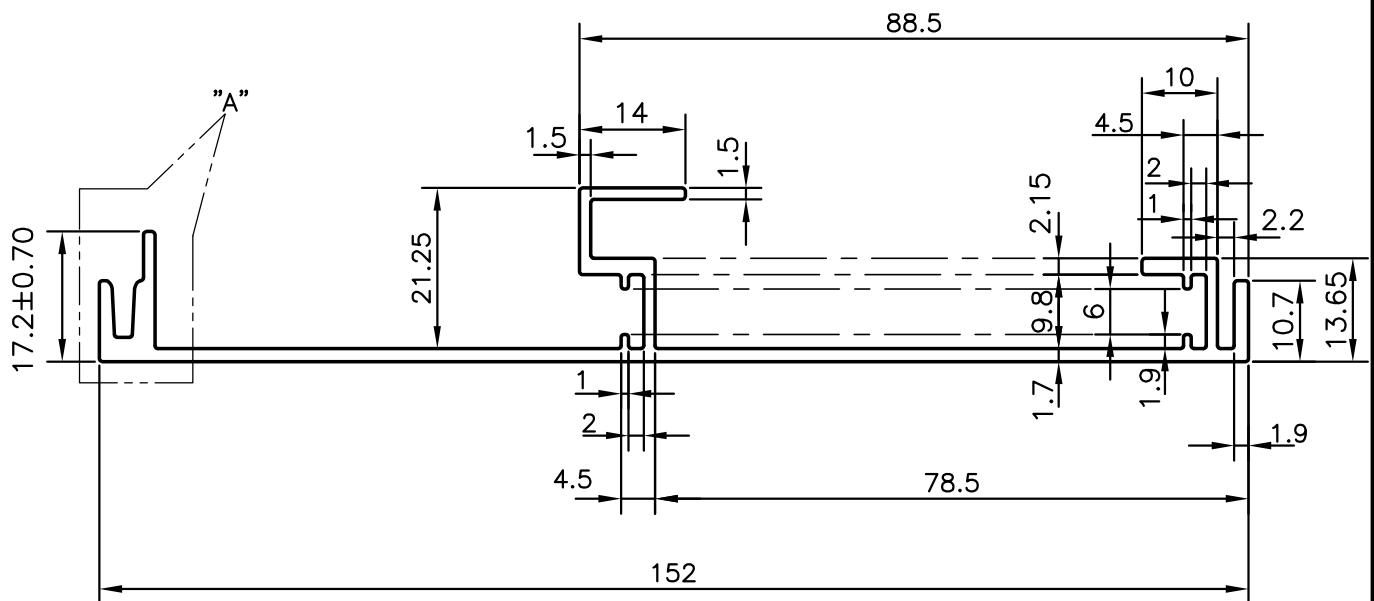
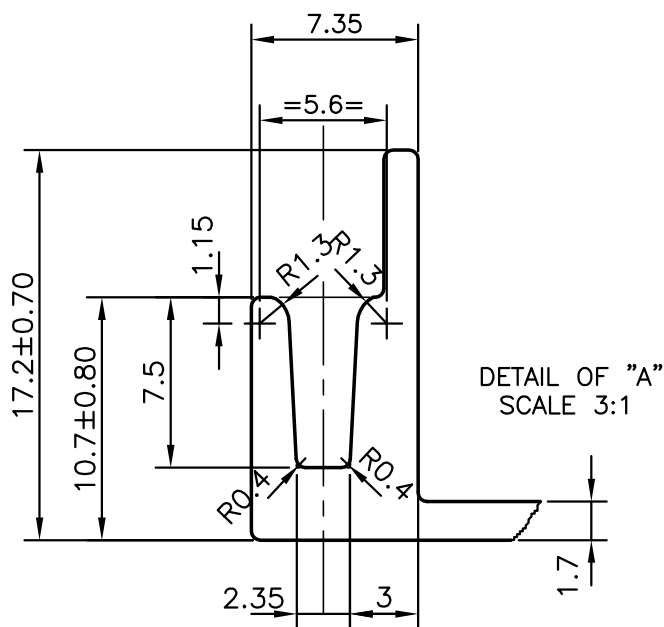

- 1 FLATNESS:- ± 0.55 mm
- 2 TWIST & BAND:- 1.7mm/M
- 3 STRAIGHTNESS:- 1.7mm/M
- 3 ANGULARITY:- $\pm 2^\circ$ /M



SYMBOL OF QUALITY
AN ISO 9001 COMPANY

JINDAL ALUMINIUM LTD.
BANGALORE-560073 (INDIA)

	NAME	DATE
DRAWN	J.P.KAUSHIK	19-06-2010
CHECKED		
APPROVED	S.S.GARG	28-06-2010
SCALE		1:1
AREA mm ²		443.139
PERIMETER mm.		502.981
WEIGHT kg/m		1.196
DRAWING No.	SECTION No.	
P-10117	-	
S2563	S2563	
29500	29500	

1. ALL DIMENSIONS ARE IN mm.
2. ROUND OFF ALL SHARP CORNERS WITH 0.40 mm.
3. TOLERANCES WILL BE AS PER IS:3965-1981 UNLESS OTHERWISE SPECIFIED

PARTY'S NAME AAF INDIA PVT.LTD., BANGALORE

PARTY'S DRAWING No. AAF-RD-EXT 027

ALLOY & TEMPER HE9 WP

DESCRIPTION 152 mm TM-RSC