

P-10121

S2565

29501

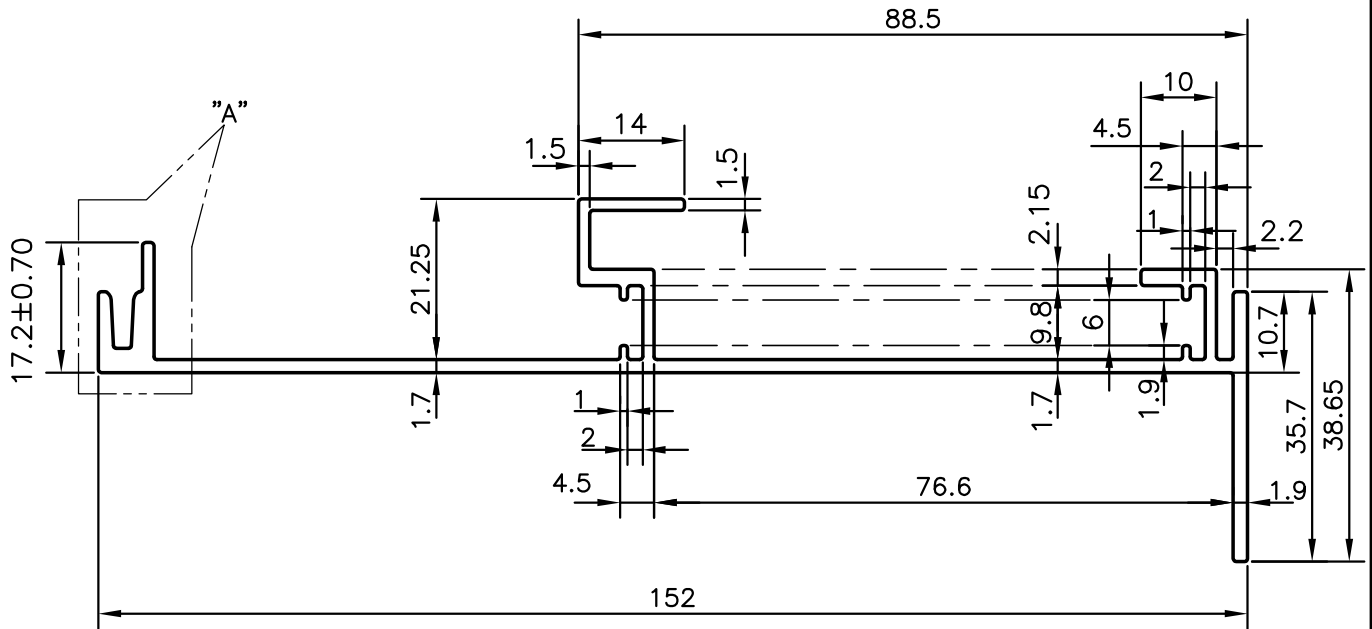
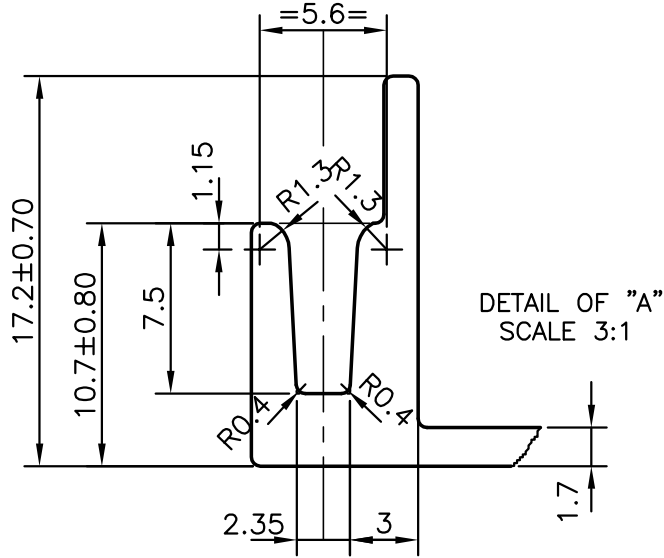

- 1 FLATNESS:- ±0.55 mm
- 2 TWIST & BAND:- 1.7mm/M
- 3 STRAIGHTNESS:- 1.7mm/M
- 3 ANGULARITY:- ±2°/M



SYMBOL OF QUALITY
AN ISO 9001 COMPANY

JINDAL ALUMINIUM LTD.
BANGALORE-560073 (INDIA)

	NAME	DATE
DRAWN	RAGHAVENDRA	21-06-2010
CHECKED		
APPROVED	S.S.GARG	28-06-2010
SCALE		1:1
AREA mm ²		490.639
PERIMETER mm.		552.638
WEIGHT kg/m		1.325
DRAWING No.	SECTION No.	
P-10121	-	
S2565	S2565	
29501	29501	

- 1. ALL DIMENSIONS ARE IN mm.
- 2. ROUND OFF ALL SHARP CORNERS WITH 0.40 mm.
- 3. TOLERANCES WILL BE AS PER DIN EN 12020 UNLESS OTHERWISE SPECIFIED

PARTY'S NAME	AAF INDIA PVT.LTD., BANGALORE
PARTY'S DRAWING No.	AAF-RD-EXT 043
ALLOY & TEMPER	HE9 WP
DESCRIPTION	152 mm TM-RSC