

P-7068

S1956

X683

29509

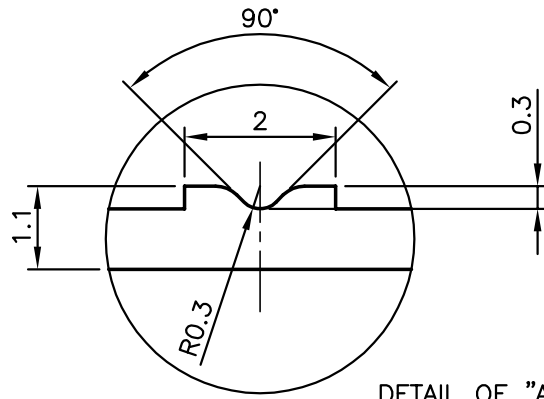
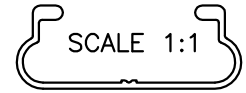

DETAIL OF "A"  
SCALE 10:1

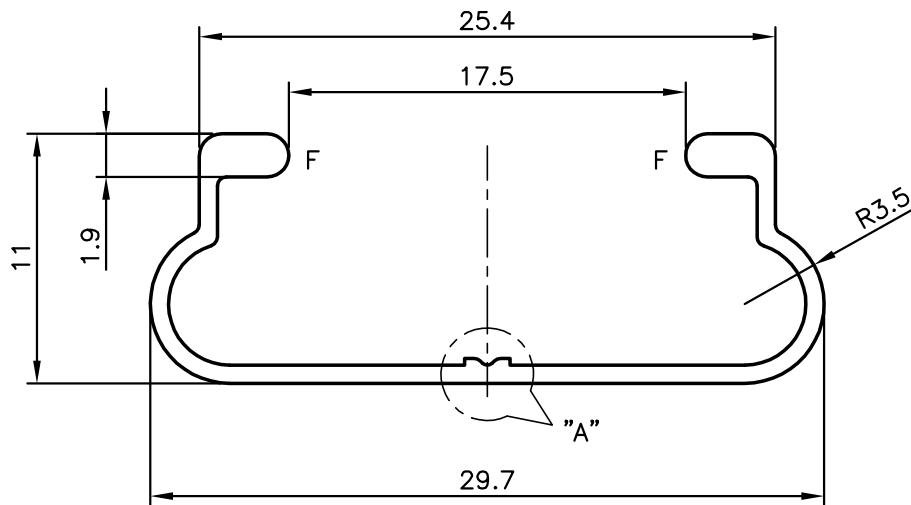

NOTE:-

1. F = FULL RADIUS (2 PLACES)
2. UNSPECIFIED WALL THICKNESS = 0.80 mm

<p>SYMBOL OF QUALITY AN ISO 9001 COMPANY</p>	<p><b>JINDAL ALUMINIUM LTD.</b> BANGALORE-560073 (INDIA)</p>	NAME		DATE
		DRAWN	PRASANN.H	26-02-2007
<p>1. ALL DIMENSIONS ARE IN mm. 2. ROUND OFF ALL SHARP CORNERS WITH 0.40 mm. 3. TOLERANCES WILL BE AS PER IS:3965-1981 UNLESS OTHERWISE SPECIFIED</p>		CHECKED		
		APPROVED		
<p>PARTY'S NAME GREEN HOUSE SOLUTION, BANGALORE</p>		SCALE		3:1
		AREA mm <sup>2</sup>		50.736
<p>PARTY'S DRAWING No. AS PER SAMPLE</p>		PERIMETER mm.		110.592
		WEIGHT kg/m		0.137
<p>ALLOY &amp; TEMPER HE9 WP</p>		DRAWING No.		P-7068
		SECTION No.		-
<p>DESCRIPTION MISC. CHANNEL</p>		S1956		S1956
		X683		X683
		29509		29509