

P-12566

29510

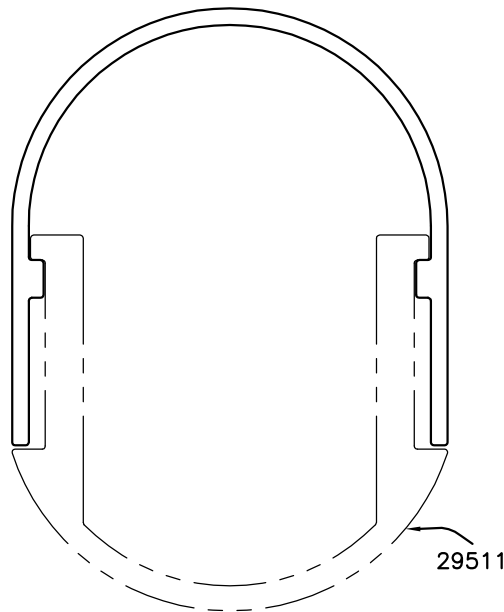
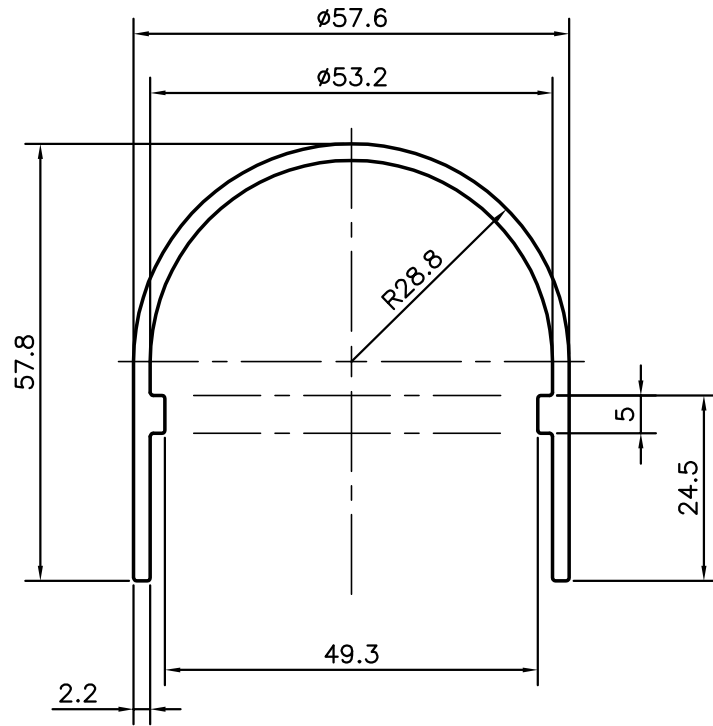

SYMBOL OF QUALITY  
AN ISO 9001 COMPANY

**JINDAL ALUMINIUM LTD.**  
BANGALORE-560073 (INDIA)

	NAME	DATE
DRAWN	<i>SRIVATHSA</i>	27-02-2013
CHECKED		
APPROVED	S.S.GARG	04-03-2013

1. ALL DIMENSIONS ARE IN mm.
2. ROUND OFF ALL SHARP CORNERS WITH 0.40 mm.
3. TOLERANCES WILL BE AS PER IS:3965-1981, UNLESS OTHERWISE SPECIFIED

SCALE	1:1
AREA mm <sup>2</sup>	338.411
PERIMETER mm.	300.184
WEIGHT kg/m	0.914

PARTY'S NAME	GENERAL CATEGORY, MUMBAI MARKET	DRAWING No.	SECTION No.
PARTY'S DRAWING No.	AS PER SAMPLE	P-12566	-
ALLOY & TEMPER	HE9 WP	29510	29510
DESCRIPTION	MISC. SECTION		