

P-11076

S3014

29536

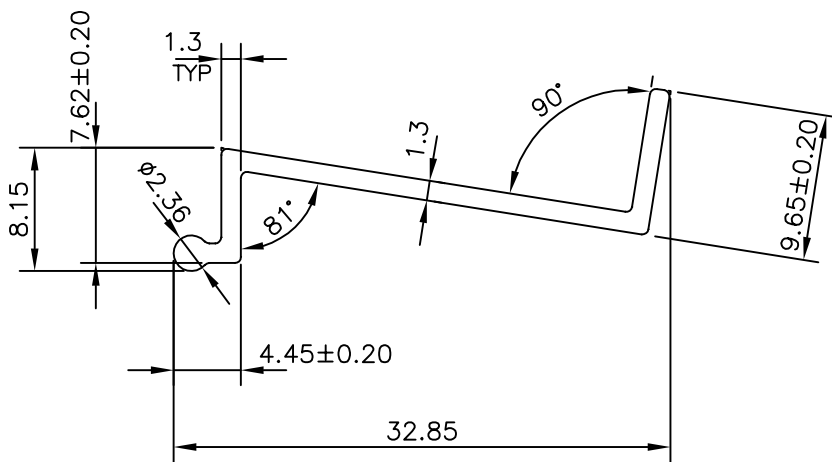

SYMBOL OF QUALITY
AN ISO 9001 COMPANY

JINDAL ALUMINIUM LTD.
BANGALORE-560073 (INDIA)

	NAME	DATE
DRAWN	J.P.KAUSHIK	08-07-2011
CHECKED		
APPROVED	S.S.GARG	29-07-2011
SCALE		2:1
AREA mm ²		61.579
PERIMETER mm.		94.123
WEIGHT kg/m		0.166
DRAWING No.	SECTION No.	
P-11076	-	
S3014	S3014	
29536	29536	

1. ALL DIMENSIONS ARE IN mm.
2. ROUND OFF ALL SHARP CORNERS WITH 0.40 mm.
3. TOLERANCES WILL BE AS PER, IS:3965-1981 UNLESS OTHERWISE SPECIFIED

PARTY'S NAME	SPX INDIA PVT LTD., JAIPUR
PARTY'S DRAWING No.	SE-01-006 REV-01
ALLOY & TEMPER	6063 T5
DESCRIPTION	MISC.SECTION