

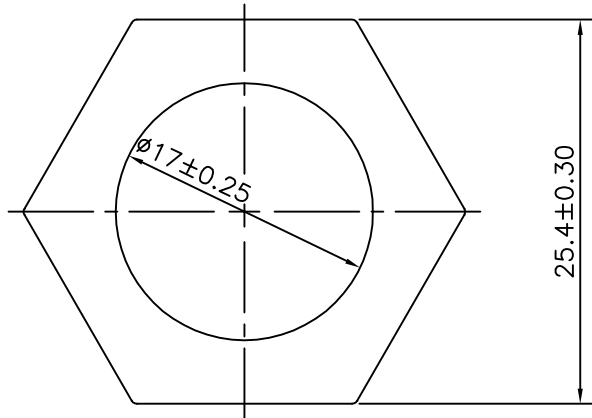

P-11188
S3047
29537

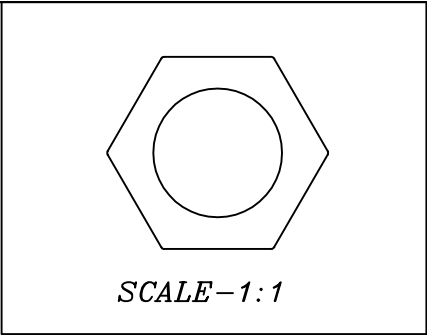

 SYMBOL OF QUALITY AN ISO 9001 COMPANY	<b>JINDAL ALUMINIUM LTD.</b> <i>BANGALORE-560073 (INDIA)</i>		NAME	DATE
		DRAWN	PARVESH	30-08-2011
1. ALL DIMENSIONS ARE IN mm. 2. ROUND OFF ALL SHARP CORNERS WITH 0.40 mm. 3. TOLERANCES WILL BE AS PER,BS:EN-755-9 UNLESS OTHERWISE SPECIFIED		CHECKED		
		APPROVED	S.S.GARG	14-09-2011
PARTY'S NAME CHAMUNDI ENGINEERING WORKS, BANGALORE		SCALE		2:1
		AREA mm <sup>2</sup>		331.693
PARTY'S DRAWING No. AS PER SPECIFICATION		PERIMETER mm.		87.73
		WEIGHT kg/m		0.896
ALLOY & TEMPER 64430 WP		DRAWING No.	SECTION No.	
		P-11188	-	
DESCRIPTION HEXAGONAL TUBE		S3047	S3047	
		29537	29537	