

P-11369-1

S3173

29543

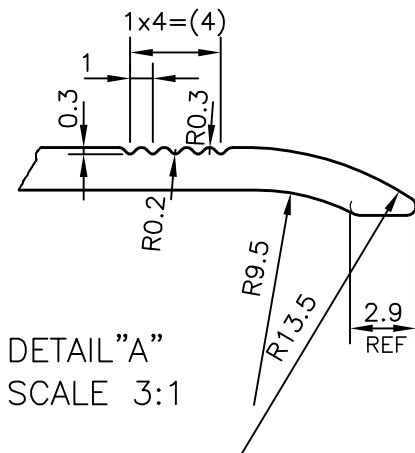
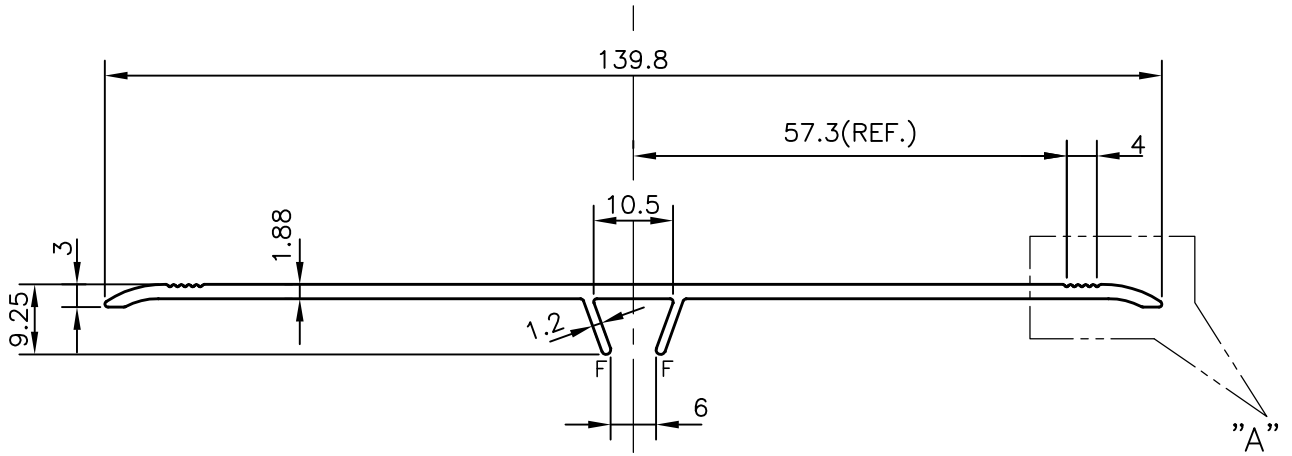

SYMBOL OF QUALITY  
AN ISO 9001 COMPANY

**JINDAL ALUMINIUM LTD.**  
BANGALORE-560073 (INDIA)

	NAME	DATE
DRAWN	J.P.KAUSHIK	15-12-2011
CHECKED		
APPROVED	S.S.GARG	02-02-2012
SCALE		1:1
AREA mm <sup>2</sup>		277.328
PERIMETER mm.		312.975
WEIGHT kg/m		0.749
DRAWING No.		SECTION No.
P-11369-1		-
S3173		S3173
29543		29543

1. ALL DIMENSIONS ARE IN mm.
2. ROUND OFF ALL SHARP CORNERS WITH 0.40 mm.
3. TOLERANCES WILL BE AS PER BS:EN-755-9 UNLESS OTHERWISE SPECIFIED

PARTY'S NAME	Z-TECH (INDIA) PVT. LTD., NEW DELHI
PARTY'S DRAWING No.	AS PER SAMPLE
ALLOY & TEMPER	6063 T6
DESCRIPTION	MISC. SECTION