

P-14096

29569

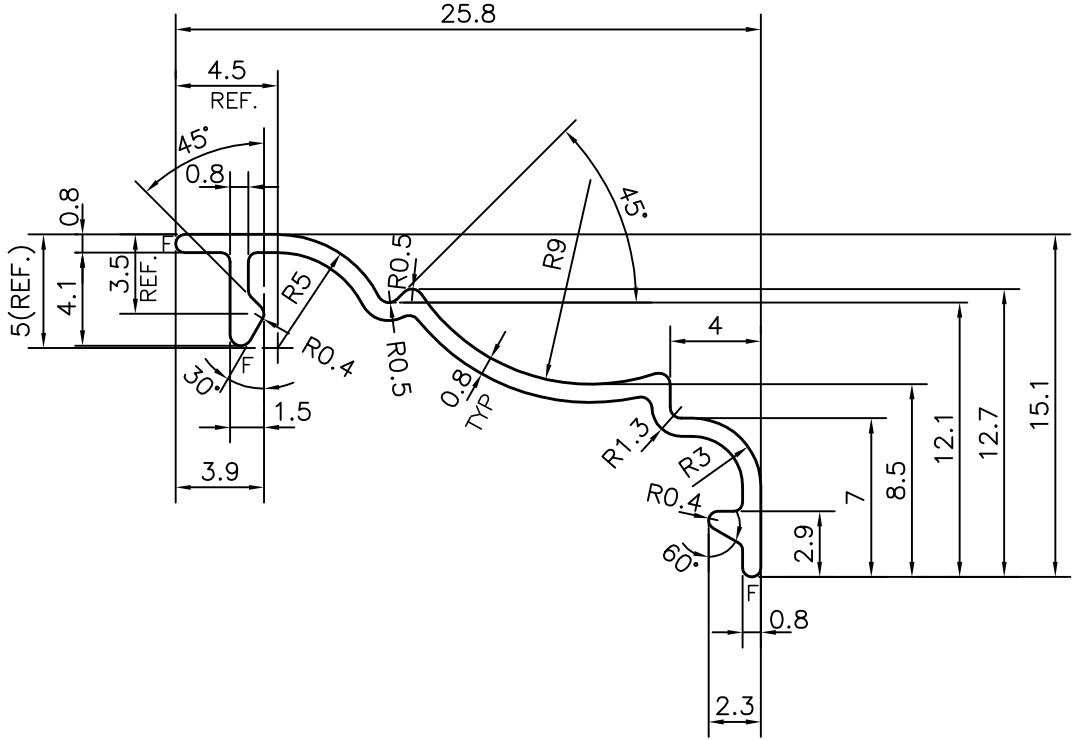

F = FULL RADIUS (3 PLACES)

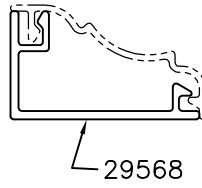
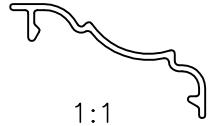

SYMBOL OF QUALITY  
AN ISO 9001 COMPANY

**JINDAL ALUMINIUM LTD.**  
BANGALORE-560073 (INDIA)

	NAME	DATE
DRAWN	J.P.KAUSHIK	12-11-2014
CHECKED		
APPROVED	S.S.GARG	21-11-2014
SCALE		3:1
AREA mm <sup>2</sup>		33.883
PERIMETER mm.		80.338
WEIGHT kg/m		0.091
DRAWING No.	SECTION No.	
P-14096	-	
29569	29569	

1. ALL DIMENSIONS ARE IN mm.
2. ROUND OFF ALL SHARP CORNERS WITH 0.40 mm.
3. TOLERANCES WILL BE AS PER IS:3965-1981, UNLESS OTHERWISE SPECIFIED

PARTY'S NAME	GENERAL CATEGORY DELHI MARKET
PARTY'S DRAWING No.	AS PER DRAWING & REQUIREMENT
ALLOY & TEMPER	HE9 WP
DESCRIPTION	MISC. SECTION