

P-13975

S4249

29583

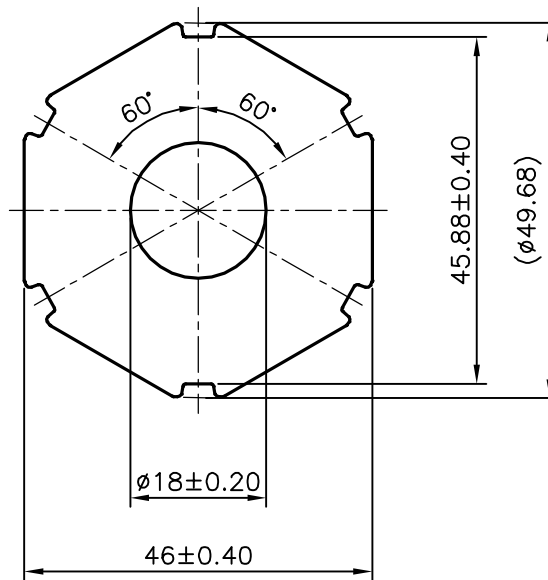
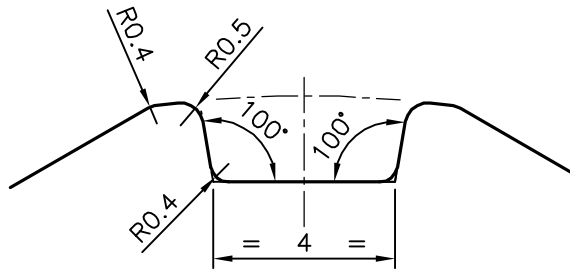

SYMBOL OF QUALITY  
AN ISO 9001 COMPANY

**JINDAL ALUMINIUM LTD.**  
BANGALORE-560073 (INDIA)

|                      | NAME        | DATE       |
|----------------------|-------------|------------|
| DRAWN                | J.P.KAUSHIK | 09-09-2014 |
| CHECKED              |             |            |
| APPROVED             | S.S.GARG    | 17-09-2014 |
| SCALE                |             | 1:1        |
| AREA mm <sup>2</sup> |             | 1496.124   |
| PERIMETER mm.        |             | 167.659    |
| WEIGHT kg/m          |             | 4.040      |
| DRAWING No.          | SECTION No. |            |
| P-13975              | -           |            |
| S4249                | S4249       |            |
| 29583                | 29583       |            |
|                      |             |            |
|                      |             |            |

1. ALL DIMENSIONS ARE IN mm.
2. ROUND OFF ALL SHARP CORNERS WITH 0.40 mm.
3. TOLERANCES WILL BE AS PER IS:6477-1983 UNLESS OTHERWISE SPECIFIED

|                     |  |
|---------------------|--|
| PARTY'S NAME        | BRITISH ENGINES INDIA PVT. LTD., BANGALORE |
| PARTY'S DRAWING No. | AS PER DRAWING                             |
| ALLOY & TEMPER      | 6262 T6                                    |
| DESCRIPTION         | HEXAGONAL TUBE                             |