

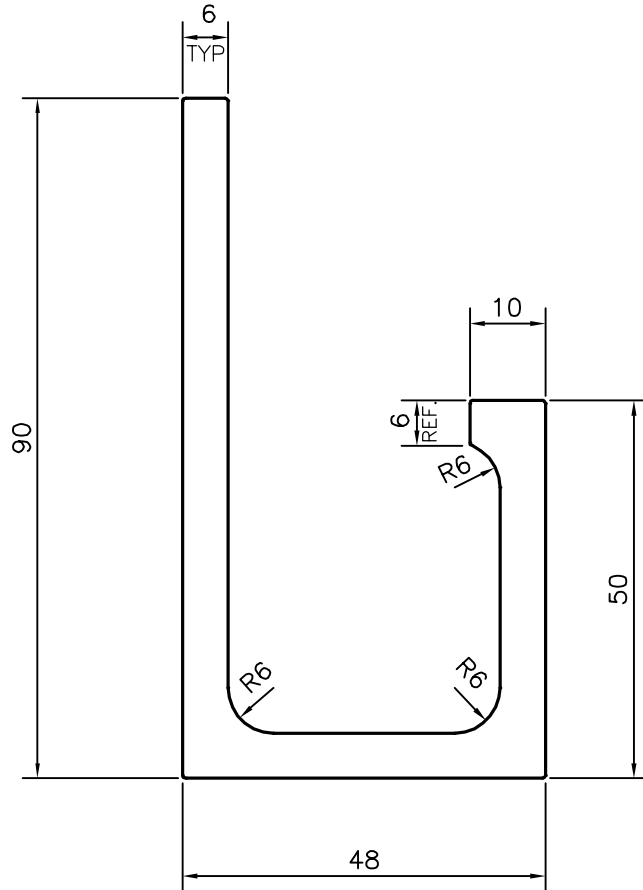

P-12259-3
S3614
29587



1. STRAIGHTNESS=0.75 mm/M
2. TWIST=1.0 mm/M
3. ANGULARITY= $\pm 1.5^\circ$

 SYMBOL OF QUALITY AN ISO 9001 COMPANY	JINDAL ALUMINIUM LTD. BANGALORE-560073 (INDIA)		NAME	DATE
		DRAWN	PARVESH	24-12-2012
1. ALL DIMENSIONS ARE IN mm. 2. ROUND OFF ALL SHARP CORNERS WITH 0.40 mm. 3. TOLERANCES WILL BE AS PER, IS:3965-1981 UNLESS OTHERWISE SPECIFIED		CHECKED		
		APPROVED	S.S.GARG	17-01-2013
PARTY'S NAME JASH ENGINEERING LTD., INDORE		SCALE		1:1
		AREA mm ²		1100.863
PARTY'S DRAWING No. JE/SG/GEN/1335		PERIMETER mm.		363.479
		WEIGHT kg/m		2.972
ALLOY & TEMPER 6061 T6		DRAWING No.	SECTION No.	
		P-12259-3	-	
DESCRIPTION SGA TOP FRAME MEMBER		S3614	S3614	
		29587	29587	