

P-11880

S4247

29597

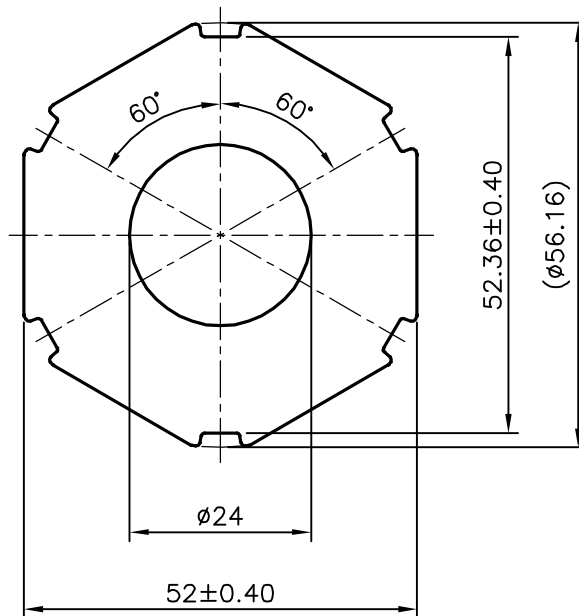
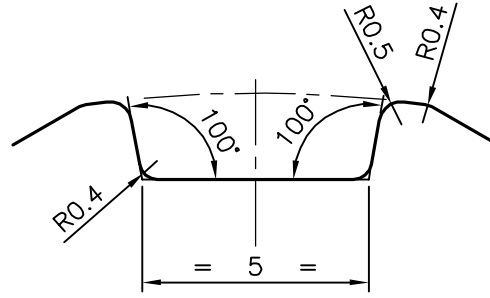

SYMBOL OF QUALITY
AN ISO 9001 COMPANY

JINDAL ALUMINIUM LTD.
BANGALORE-560073 (INDIA)

	NAME	DATE
DRAWN	J.P.KAUSHIK	27-06-2012
CHECKED		
APPROVED	S.S.GARG	17-09-2014
SCALE		1:1
AREA mm ²		1787.376
PERIMETER mm.		187.267
WEIGHT kg/m		4.826
DRAWING No.	SECTION No.	

1. ALL DIMENSIONS ARE IN mm.
2. ROUND OFF ALL SHARP CORNERS WITH 0.40 mm.
3. TOLERANCES WILL BE AS PER IS:6477-1983 UNLESS OTHERWISE SPECIFIED

PARTY'S NAME	BRITISH ENGINES INDIA PVT. LTD., BANGALORE
PARTY'S DRAWING No.	AS PER SPECIFICATION & OUR SECTION No29400
ALLOY & TEMPER	6262 T6
DESCRIPTION	HEXAGONAL TUBE

P-11880	-
S4247	S4247
29597	29597