

P-14775

29598

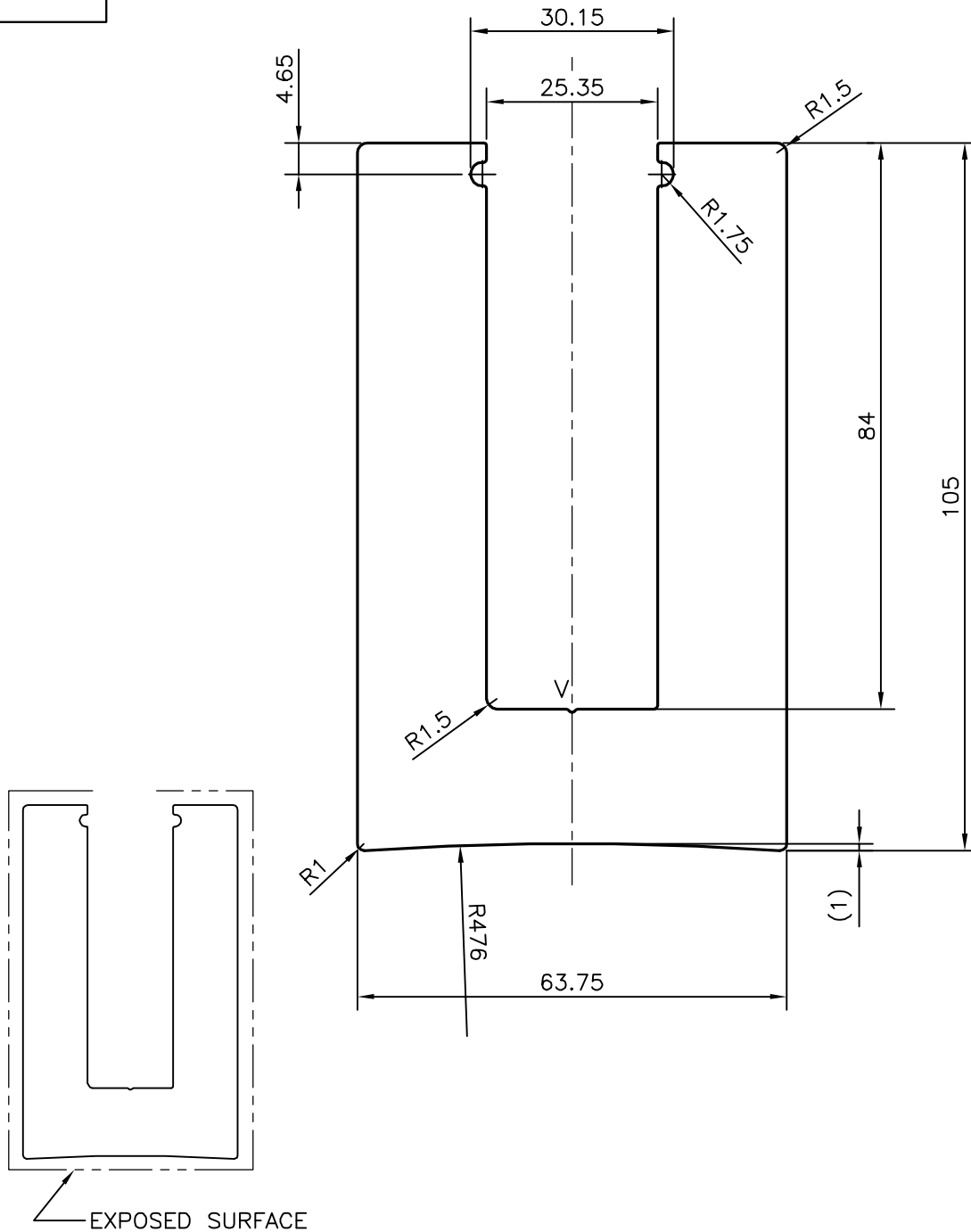

V = V GROOVE 0.5x90°



SYMBOL OF QUALITY
AN ISO 9001 COMPANY

JINDAL ALUMINIUM LTD.
BANGALORE-560073 (INDIA)

	NAME	DATE
DRAWN	J.P.KAUSHIK	20-06-2015
CHECKED		
APPROVED	S.S.GARG	24-06-2015
SCALE		1:1
AREA mm ²		4507.518
PERIMETER mm.		508.441
WEIGHT kg/m		12.170
DRAWING No.	SECTION No.	
P-14775		
29598	29598	

1. ALL DIMENSIONS ARE IN mm.
2. ROUND OFF ALL SHARP CORNERS WITH 0.40 mm.
3. TOLERANCES WILL BE AS PER IS:3965-1981 UNLESS OTHERWISE SPECIFIED

PARTY'S NAME	GENERAL CATEGORY, DELHI MARKET
PARTY'S DRAWING No.	AS PER SAMPLE
ALLOY & TEMPER	HE9 WP
DESCRIPTION	MISC. CHANNEL