

P-15489

29614

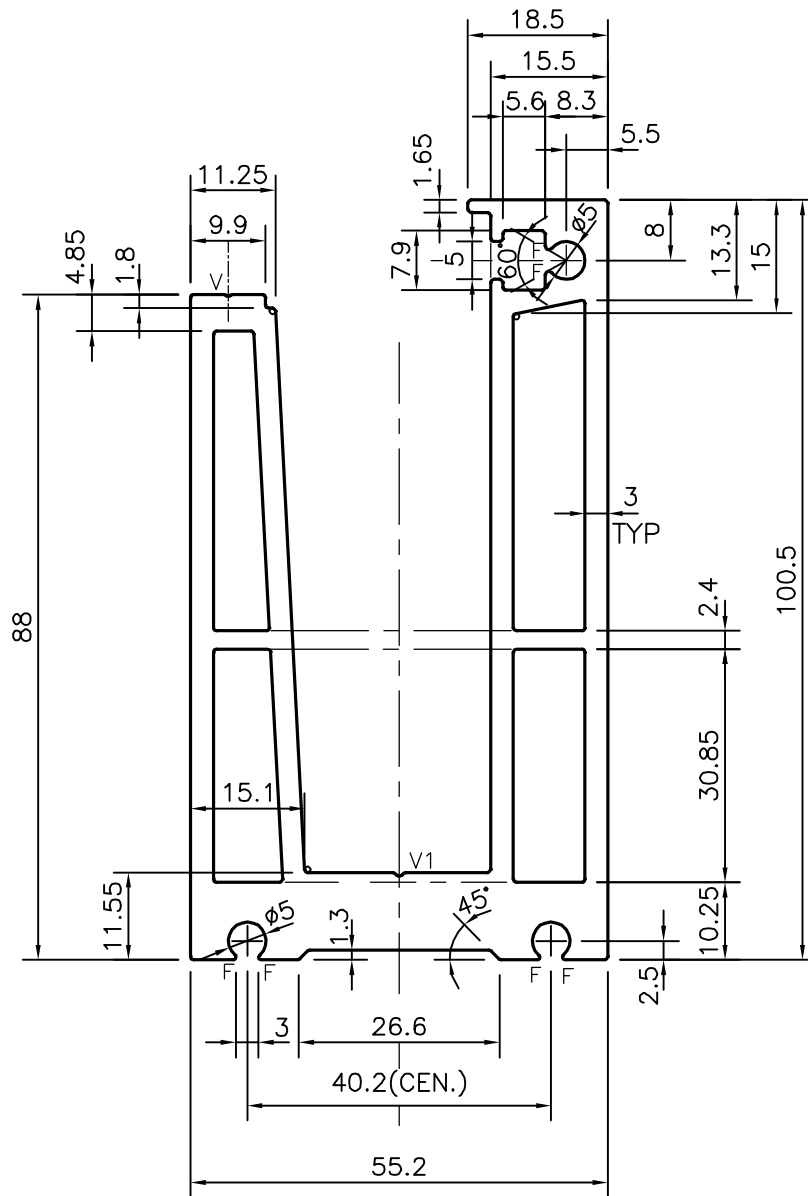

V1 = V GROOVE 0.5x90°
 V = V GROOVE 0.3x90°
 F = FULL RADIUS (6 PLACES)



SYMBOL OF QUALITY
 AN ISO 9002 COMPANY

JINDAL ALUMINIUM LTD.
 BANGALORE-560073 (INDIA)

	NAME	DATE
DRAWN	J.P.KAUSHIK	08-01-2016
CHECKED		
APPROVED	S.S.GARG	11-01-2016
SCALE		1:1
AREA mm ²		1662.691
PERIMETER mm.		516.036
WEIGHT kg/m		4.489
DRAWING No.	SECTION No.	
P-15489	-	
29614	29614	

1. ALL DIMENSIONS ARE IN mm.
2. ROUND OFF ALL SHARP CORNERS WITH 0.40 mm.
3. TOLERANCES WILL BE AS PER IS:6477-1983 UNLESS OTHERWISE SPECIFIED

PARTY'S NAME	GENERAL CATEGORY, MUMBAI MARKET
PARTY'S DRAWING No.	AS PER SAMPLE
ALLOY & TEMPER	HE9 WP
DESCRIPTION	MISC. SECTION