

P-15491

29615

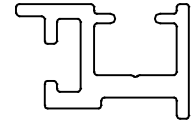

1:1

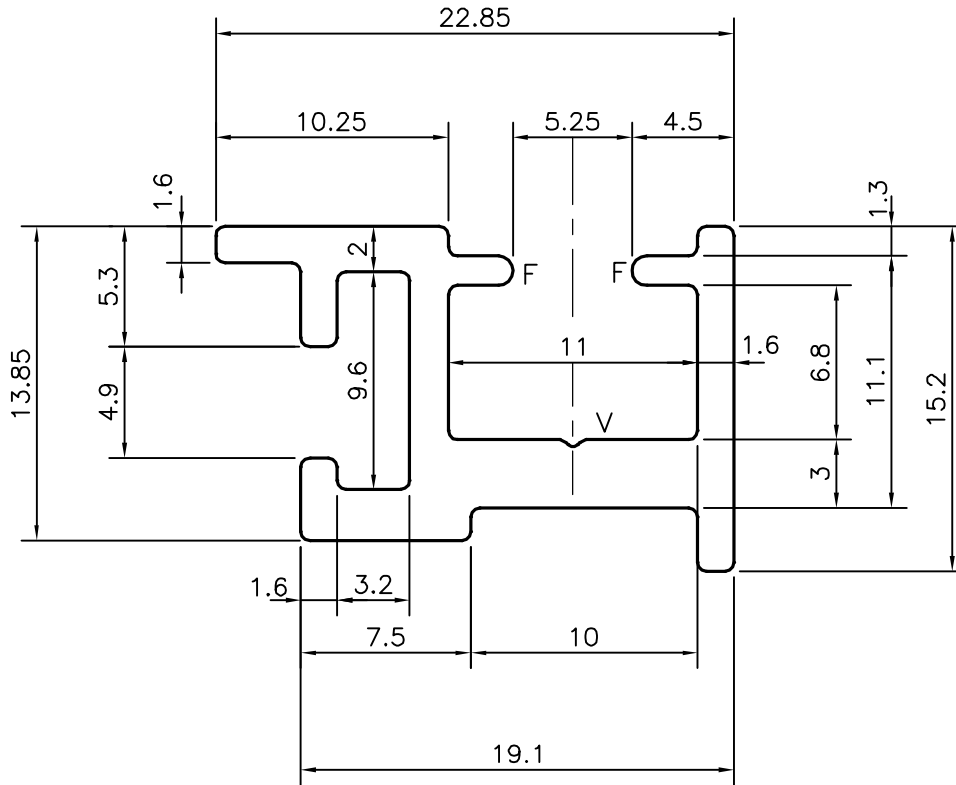

V = V GROOVE 0.3x90°
 F = FULL RADIUS (2 PLACES)



SYMBOL OF QUALITY
 AN ISO 9002 COMPANY

JINDAL ALUMINIUM LTD.
 BANGALORE-560073 (INDIA)

	NAME	DATE
DRAWN	J.P.KAUSHIK	08-01-2016
CHECKED		
APPROVED	S.S.GARG	11-01-2016
SCALE		3:1
AREA mm ²		123.18
PERIMETER mm.		122.909
WEIGHT kg/m		0.333
DRAWING No.	SECTION No.	
P-15491	-	
29615	29615	

1. ALL DIMENSIONS ARE IN mm.
2. ROUND OFF ALL SHARP CORNERS WITH 0.40 mm.
3. TOLERANCES WILL BE AS PER IS:3965-1981 UNLESS OTHERWISE SPECIFIED

PARTY'S NAME	GENERAL CATEGORY, MUMBAI MARKET
PARTY'S DRAWING No.	AS PER SAMPLE
ALLOY & TEMPER	HE9 WP
DESCRIPTION	MISC. SECTION