

P-15588-1

29616

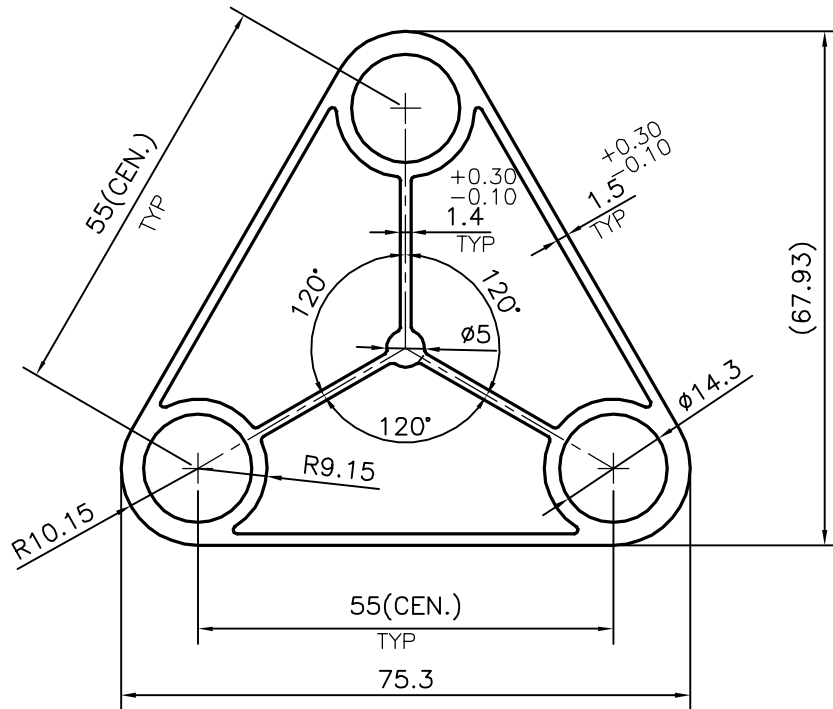

UNSPECIFIED RADIUS 0.5 mm



SYMBOL OF QUALITY
AN ISO 9001 COMPANY

JINDAL ALUMINIUM LTD.
BANGALORE-560073 (INDIA)

	NAME	DATE
DRAWN	J.P.KAUSHIK	10-02-2016
CHECKED		
APPROVED	B. NATARAJ	20-02-2016
SCALE		1:1
AREA mm ²		717.988
PERIMETER mm.		228.768
WEIGHT kg/m		1.939
DRAWING No.	SECTION No.	
P-15588-1	-	
29616	29616	

1. ALL DIMENSIONS ARE IN mm.
2. ROUND OFF ALL SHARP CORNERS WITH 0.40 mm.
3. TOLERANCES WILL BE AS PER, IS:6477-1983 UNLESS OTHERWISE SPECIFIED

PARTY'S NAME	GENERAL CATEGORY, DELHI MARKET
PARTY'S DRAWING No.	AS PER DRAWING & REQUIREMENT
ALLOY & TEMPER	HE9 WP
DESCRIPTION	TRIANGULAR TUBE