

P-15554-2

29617

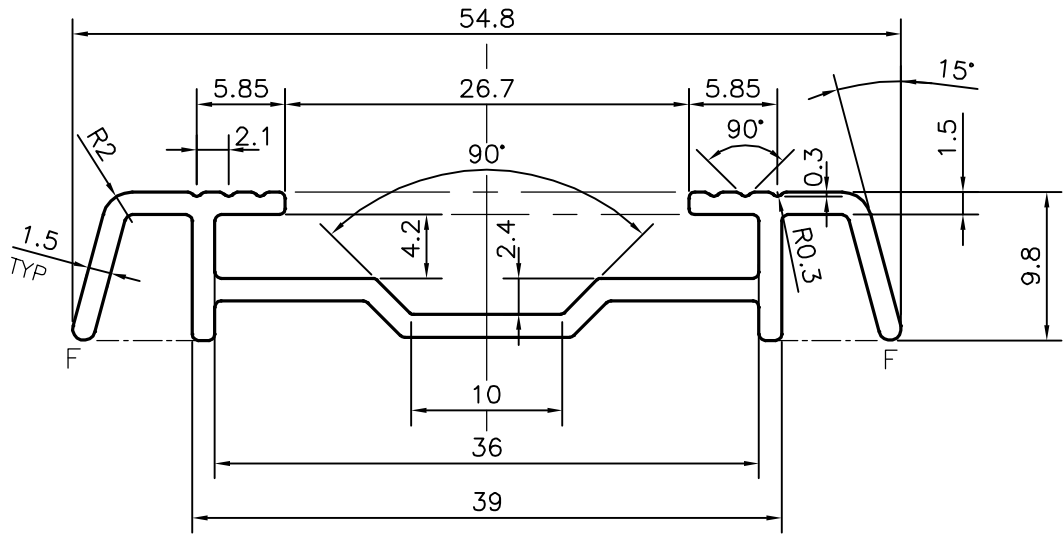

1:1



F = FULL RADIUS (2 PLACES)



SYMBOL OF QUALITY
AN ISO 9001 COMPANY

JINDAL ALUMINIUM LTD.
BANGALORE-560073 (INDIA)

	NAME	DATE
DRAWN	J.P.KAUSHIK	19-02-2016
CHECKED		
APPROVED	S.S.GARG	23-02-2016
SCALE		2:1
AREA mm ²		140.804
PERIMETER mm.		189.681
WEIGHT kg/m		0.380
DRAWING No.	SECTION No.	
P-15554-2	-	
29617	29617	

1. ALL DIMENSIONS ARE IN mm.
2. ROUND OFF ALL SHARP CORNERS WITH 0.40 mm.
3. TOLERANCES WILL BE AS PER, IS:3965-1981 UNLESS OTHERWISE SPECIFIED

PARTY'S NAME	GENERAL CATEGORY, MUMBAI MARKET
PARTY'S DRAWING No.	AS PER SAMPLE & REQUIREMENT
ALLOY & TEMPER	HE9 WP
DESCRIPTION	MISC. SECTION