

P-14631

S4488

29618

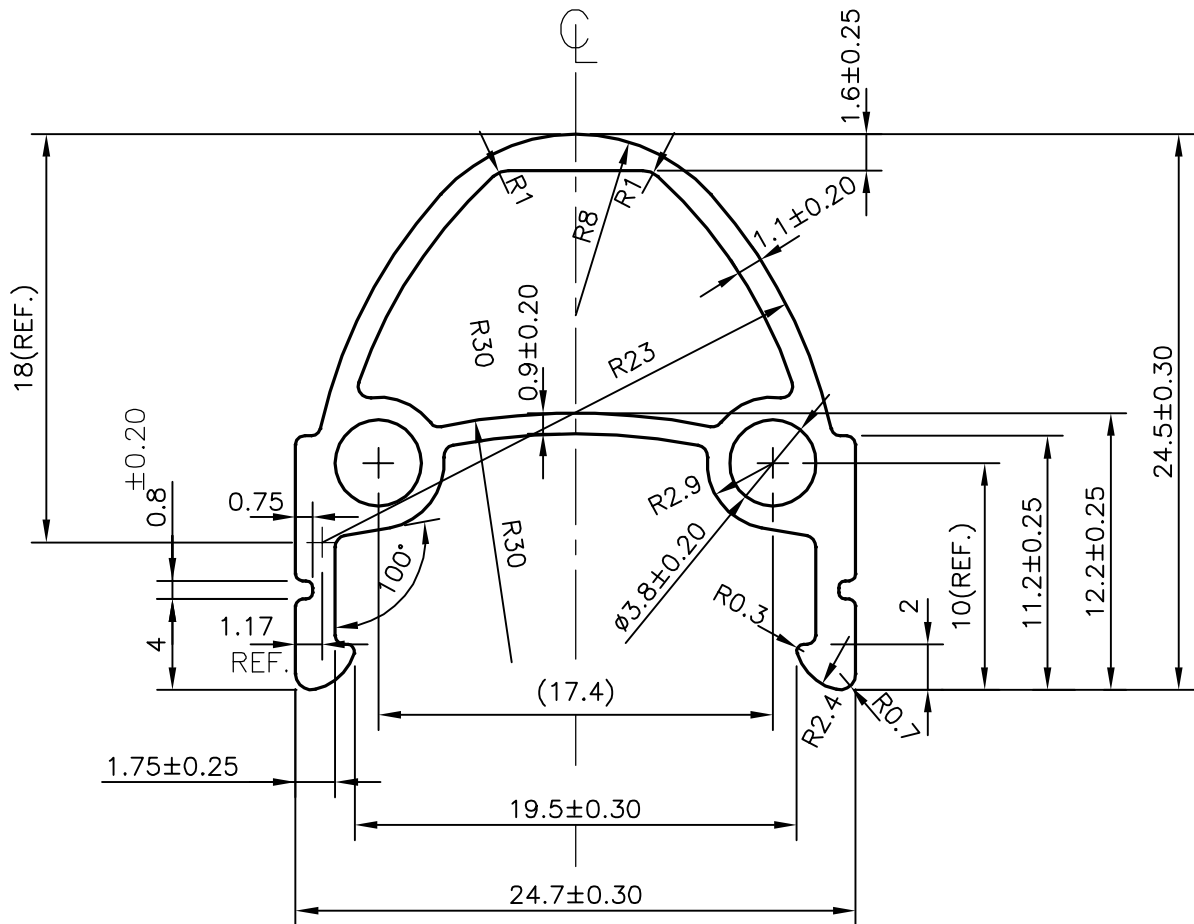
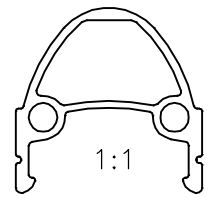

1. STRAIGHTNESS=1.5mm/M
2. TWIST=1.5mm/M
3. ANGULARITY= ±1.5°
4. FLATNESS =N/A



SYMBOL OF QUALITY
AN ISO 9001 COMPANY

JINDAL ALUMINIUM LTD.
BANGALORE-560073 (INDIA)

	NAME	DATE
DRAWN	J.P.KAUSHIK	07-05-2015
CHECKED		
APPROVED	S.S.GARG	13-06-2015
SCALE		3:1
AREA mm ²		115.641
PERIMETER mm.		106.324
WEIGHT kg/m		0.312
DRAWING No.	SECTION No.	
P-14631	-	
S4488	S4488	
29618	29618	

1. ALL DIMENSIONS ARE IN mm.
2. ROUND OFF ALL SHARP CORNERS WITH 0.40 mm.
3. TOLERANCES WILL BE AS PER IS:6477-1983 UNLESS OTHERWISE SPECIFIED

PARTY'S NAME	HERO CYCLES LTD., LUDHIANA
PARTY'S DRAWING No.	DSTD-22-014A
ALLOY & TEMPER	6063 T6
DESCRIPTION	RIM SECTION