

P-14632

S4489

29619

1. STRAIGHTNESS=1.5mm/M
2. TWIST=1.5mm/M
3. ANGULARITY= $\pm 1.5^\circ$
4. FLATNESS =N/A

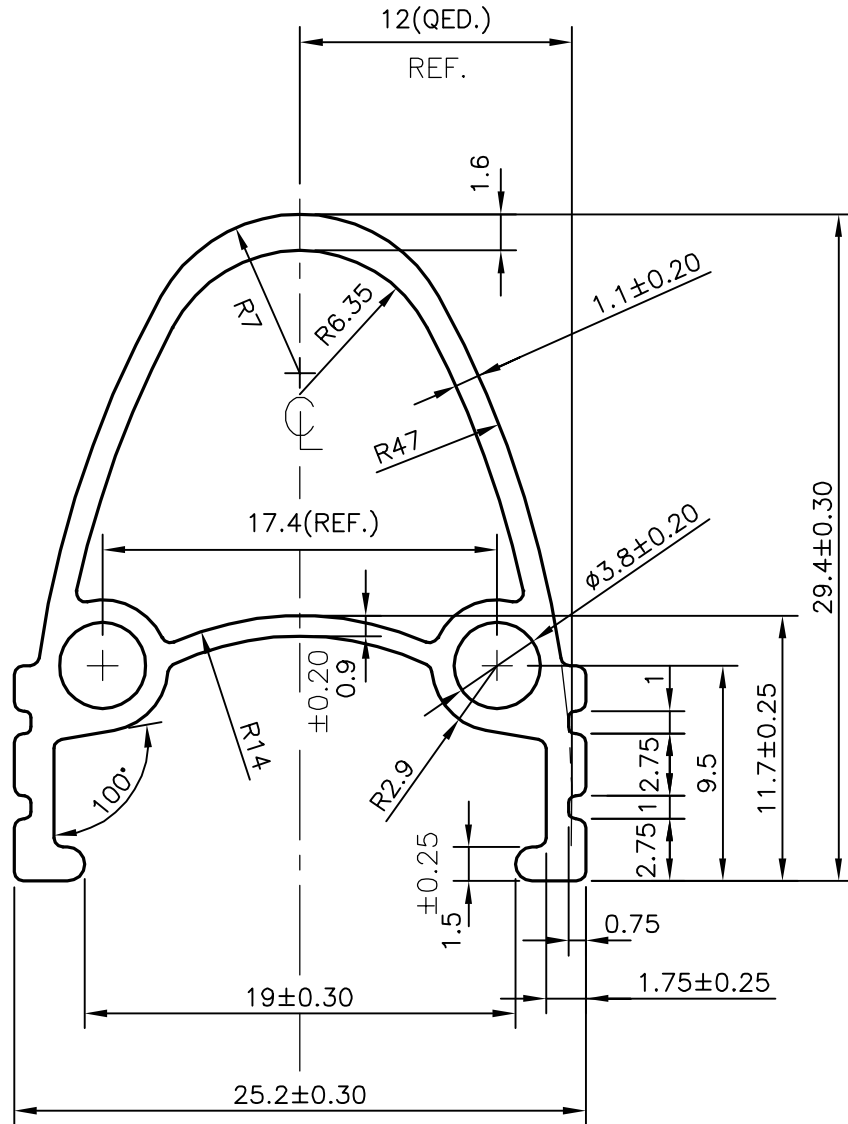
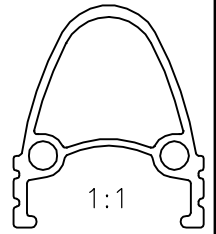

SYMBOL OF QUALITY
AN ISO 9001 COMPANY

JINDAL ALUMINIUM LTD.
BANGALORE-560073 (INDIA)

	NAME	DATE
DRAWN	J.P.KAUSHIK	07-05-2015
CHECKED		
APPROVED	S.S.GARG	13-06-2015

1. ALL DIMENSIONS ARE IN mm.
2. ROUND OFF ALL SHARP CORNERS WITH 0.40 mm.
3. TOLERANCES WILL BE AS PER IS:6477-1983 UNLESS OTHERWISE SPECIFIED

SCALE	3:1
AREA mm ²	127.417
PERIMETER mm.	117.91
WEIGHT kg/m	0.344

PARTY'S NAME HERO CYCLES LTD., LUDHIANA

DRAWING No. SECTION No.

PARTY'S DRAWING No. DSTD-22-013A

P-14632

S4489

29619

-

S4489

29619

ALLOY & TEMPER 6063 T6

DESCRIPTION

RIM SECTION