

P-16245

29648

DETAIL OF "A"
SCALE 3:1

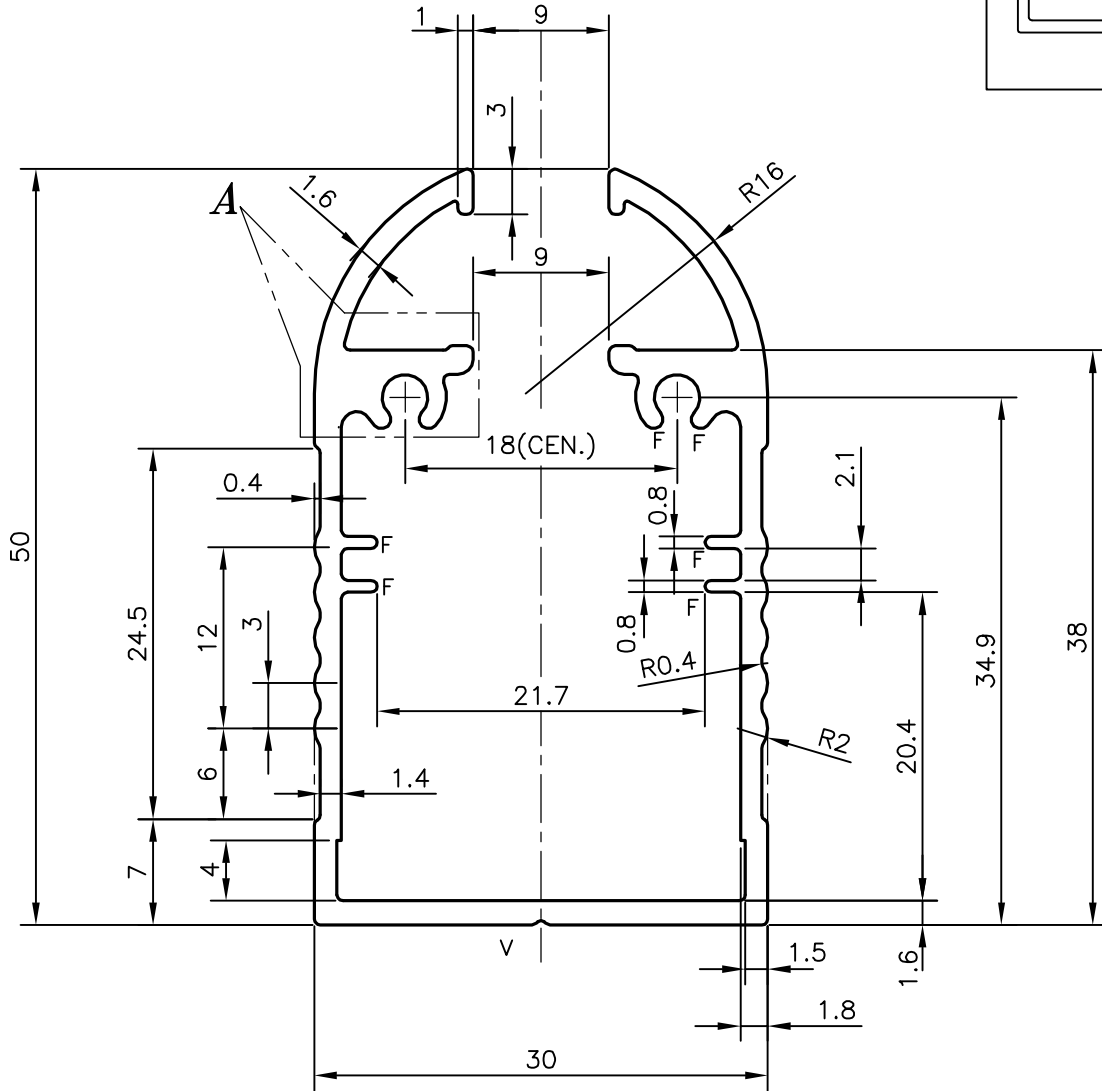
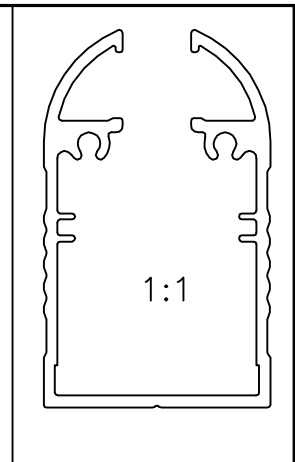
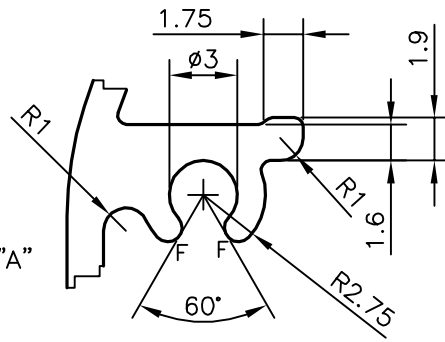

V = V GROOVE 0.3x90° (1 PLACES)
F = FULL RADIUS (8 PLACES)



SYMBOL OF QUALITY
AN ISO 9001 COMPANY

JINDAL ALUMINIUM LTD.
BANGALORE-560073 (INDIA)

	NAME	DATE
DRAWN	J.P.KAUSHIK	20-08-2016
CHECKED		
APPROVED	S.S. GARG	23-08-2016
SCALE		2:1
AREA mm ²		277.706
PERIMETER mm.		340.039
WEIGHT kg/m		0.750
DRAWING No.	SECTION No.	
P-16245	-	
29648	29648	

1. ALL DIMENSIONS ARE IN mm.
2. ROUND OFF ALL SHARP CORNERS WITH 0.40 mm.
3. TOLERANCES WILL BE AS PER IS:3965-1981 UNLESS OTHERWISE SPECIFIED

PARTY'S NAME	GENERAL CATEGORY, BANGALORE MARKET
PARTY'S DRAWING No.	AS PER SAMPLE
ALLOY & TEMPER	HE9 WP
DESCRIPTION	MISC. SECTION