

P-17626

29662

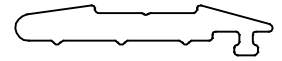

1:1

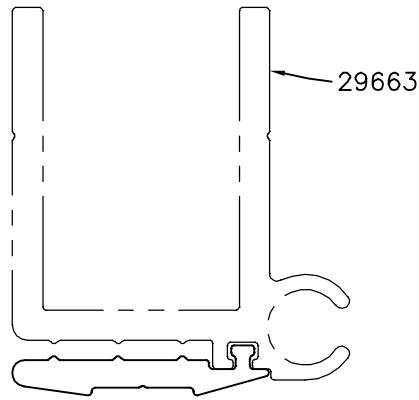
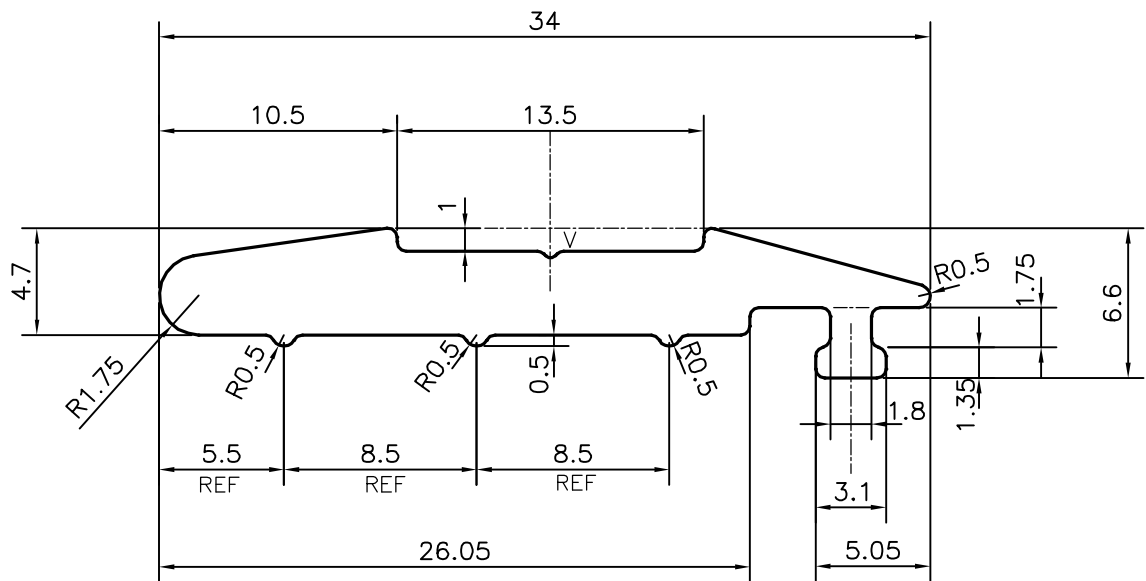

V = V GROOVE 0.3x90° (ONE PLACE)

TOLERANCES ON OVERALL WIDTHS & WIDTHS ACROSS FLATS OF BARS, & REGULAR SECTIONS

| | | | |
|---------------------|----------------------|----------------------|---|
| UPTO 6.40mm - ±0.20 | UPTO 32.0mm - ±0.38 | UPTO 120.0mm - ±0.85 | 1. STRAIGHTNESS=1.7mm/M 2. TWIST=1.7mm/M 3. ANGULARITY= ±2° 4. FLATNESS =0.007xWIDTH |
| UPTO 10.0mm - ±0.23 | UPTO 50.0mm - ±0.46 | UPTO 160.0mm - ±1.02 | |
| UPTO 12.0mm - ±0.25 | UPTO 60.0mm - ±0.53 | UPTO 200.0mm - ±1.14 | |
| UPTO 16.0mm - ±0.28 | UPTO 80.0mm - ±0.69 | UPTO 250.0mm - ±1.40 | |
| UPTO 25.0mm - ±0.30 | UPTO 100.0mm - ±0.75 | UPTO 300.0mm - ±1.65 | |



SYMBOL OF QUALITY
AN ISO 9001 COMPANY

JINDAL ALUMINIUM LTD.
BANGALORE-560073 (INDIA)

| | NAME | DATE |
|----------|-------------|------------|
| DRAWN | J.P.KAUSHIK | 20-11-2017 |
| CHECKED | | |
| APPROVED | J.N.RAI | 24-11-2017 |

1. ALL DIMENSIONS ARE IN mm.
2. ROUND OFF ALL SHARP CORNERS WITH 0.40 mm.
3. TOLERANCES WILL BE AS PER IS:3965-1981, UNLESS OTHERWISE SPECIFIED

| | |
|----------------------|--------|
| SCALE | 3:1 |
| AREA mm ² | 124.29 |
| PERIMETER mm. | 81.96 |
| WEIGHT kg/m | 0.336 |

| | |
|---------------------|------------------------------------|
| PARTY'S NAME | GENERAL CATEGORY, BANGALORE MARKET |
| PARTY'S DRAWING No. | AS PER DRAWING |
| ALLOY & TEMPER | 6063 T6 |
| DESCRIPTION | MISC. SECTION |

| DRAWING No. | SECTION No. |
|-------------|-------------|
| P-17626 | - |
| 29662 | 29662 |